

**RESEARCH ARTICLE**

# Electromagnetic modeling and design of a novel class of complementary split-ring resonators

Enrique J. Rubio Martínez-Dueñas<sup>1</sup> | Carlos Moreno de Jong van Coevorden<sup>2</sup> | Oleg V. Stukach<sup>3</sup> | Nikolay V. Panokin<sup>4</sup> | Johan Gielis<sup>2,5</sup> | Diego Caratelli<sup>2,6,7</sup> 

<sup>1</sup>University of Granada, Granada, Spain

<sup>2</sup>The Antenna Company, Eindhoven, The Netherlands

<sup>3</sup>Higher School of Economics (HSE), National Research University, Moscow, Russia

<sup>4</sup>National University of Science and Technology MISiS, Moscow, Russia

<sup>5</sup>University of Antwerp, Antwerp, Belgium

<sup>6</sup>Eindhoven University of Technology, Eindhoven, The Netherlands

<sup>7</sup>Tomsk Polytechnic University, Tomsk, Russia

## Abstract

This research study reports the assessment of complementary split ring resonators based on Gielis transformation as basic elements for the design of high-performance microwave components in printed technology. From the electromagnetic simulation of said structures, suitable equivalent circuit models are extracted and analyzed. Physical prototypes are fabricated and tested for design validation. The obtained results confirm that the adoption of supershaped geometries enables the synthesis of very compact scalable microwave filters.

## KEYWORDS

complementary split-ring resonator, equivalent circuit, Gielis formula, metamaterials, microwave filter

## 1 | INTRODUCTION

Split ring resonators (SRRs) have been originally proposed as metamaterial structures featuring double negative medium properties,<sup>1–3</sup> whereas their complementary variant complementary split ring resonators (CSRRs) are typically utilized as negative-permittivity components in planar left-handed structures for synthesis of artificial transmission lines and complex microwave passive components such as multiband impedance inverters.<sup>4,5</sup> In particular, the use of SRRs and CSRRs as basic resonant units in planar microwave filters has gained a progressively growing interest thanks to their electrically small size when compared to conventional resonators, this enabling the realization of semilumped filtering structures with high performance and controllable characteristics.<sup>6–11</sup>

Canonical circular or square geometries are commonly adopted for the design of the considered class of resonators. More recently, Sierpinsky fractal geometries have been proposed for the realization of miniaturized CSRRs still with a square-like form factor.<sup>12</sup> It is to be noticed that squares and circles may be

regarded as special cases of the Gielis equation,<sup>13</sup> so the question arises whether higher-order supershaped geometries could provide benefits or additional degrees of freedom in the synthesis of highly compact planar microwave filters. The goal of this study is therefore to analyze the performance of bandpass CSRR filters whose geometry is based on Gielis formula.

The article is organized as follows. A detailed description of the geometry of the considered CSRR unit cells, as well as of the equivalent circuit models used to investigate the relevant electromagnetic properties is given in section 2. Measurement results are presented and discussed in section 3. Finally, the concluding remarks and outline of future work are summarized in section 4.

## 2 | SUPERSHAPED CSRR

### 2.1 | Geometrical foundation of the design

Gielis formula is a generalization of Lamé equation that can be used to describe a wide variety of complex shapes found

in Nature. Its general expression is reported in Ref. 13. In this study, we are making use of the following particular case:

$$\begin{aligned} \rho = r_m(\varphi) &= \frac{1}{2} \lim_{n \rightarrow +\infty} \left( \left| \cos \frac{m\varphi}{4} \right|^n + \left| \sin \frac{m\varphi}{4} \right|^n \right)^{-\frac{1}{n}} \\ &= \frac{1}{2} \min \left\{ \left| \sec \frac{m\varphi}{4} \right|, \left| \csc \frac{m\varphi}{4} \right| \right\}, \end{aligned} \quad (1)$$

with  $\rho$  and  $\varphi$  denoting the usual polar coordinates defined with respect to a background Cartesian reference frame  $Oxy$ , and where  $m$  is a positive integer parameter which defines the number of pseudovertices featured by the general closed curve  $C_m$  described by (1).

It is known from the basic theory of differential geometry that the length and area of  $C_m$  are given, respectively, by:

$$\ell_m = \int_0^{2\pi} \sqrt{r_m^2(\varphi) + \left[ \frac{dr_m(\varphi)}{d\varphi} \right]^2} d\varphi, \quad (2)$$

$$A_m = \frac{1}{2} \int_0^{2\pi} r_m^2(\varphi) d\varphi. \quad (3)$$

By making use of (2) and (3), it can be found out, after simple algebra, that the considered class of supershaped curves is characterized by unitary area  $A_m = 1$  for  $m > 0$ , whereas the length can be computed as:

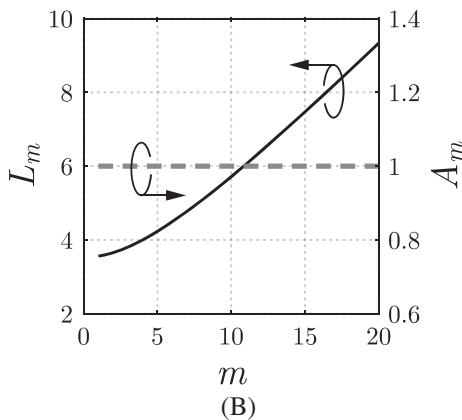
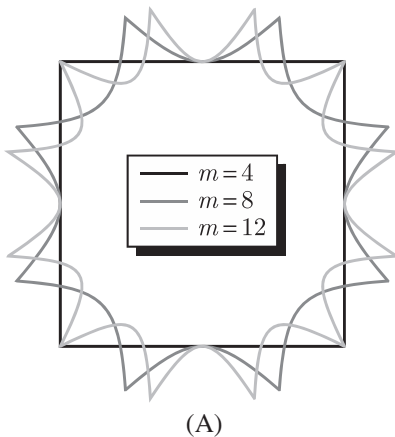

**FIGURE 1** Supershaped closed curves  $C_m$  (A) and relevant length  $\ell_m$  and area  $A_m$  (B) for different values of the Gielis order  $m$

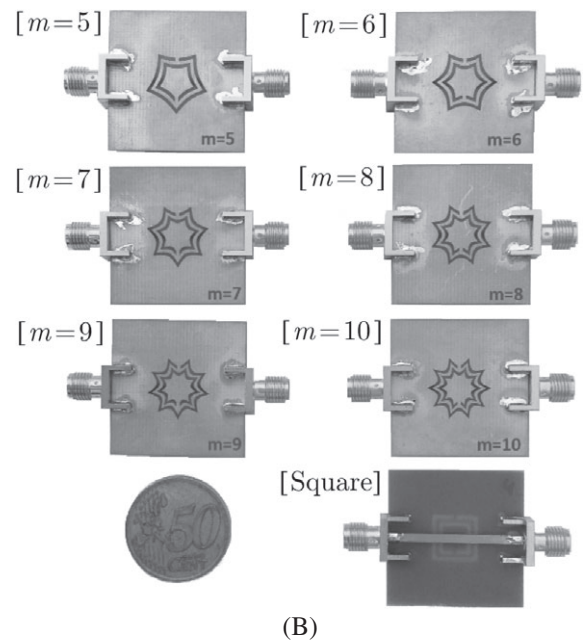
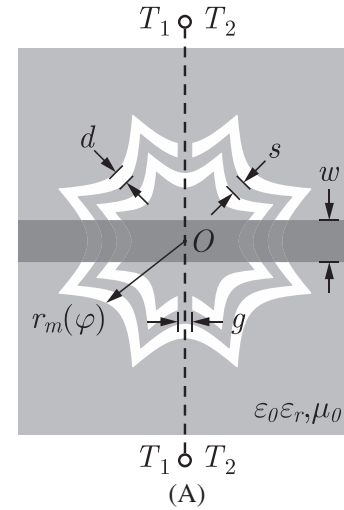

**FIGURE 2** Topology (A) and physical prototypes (B) of supershaped complementary split ring resonators-based stop-band filters realized in microstrip technology

$$\ell_m = \sqrt{8 + \frac{m^2}{2}} + 4 \left[ F\left(\frac{\pi}{4} \middle| 1 - \frac{m^2}{16}\right) - E\left(\frac{\pi}{4} \middle| 1 - \frac{m^2}{16}\right) \right], \quad (4)$$

with  $F(\cdot | \cdot)$  and  $E(\cdot | \cdot)$  being the elliptic integral of the first and second kind, respectively. It is apparent from (4) that  $\ell_m$  increases asymptotically with linear law, namely  $\ell_m \propto (\sqrt{2}-1)m$  as  $m \rightarrow +\infty$  (see Figure 1).

## 2.2 | Physical implementation

The microwave filters investigated in this study consist of a microstrip transmission line loaded with a supershaped CSRR of general Gielis order  $m$  etched in the relevant ground plane, as shown in Figure 2A.

The considered structure is realized on dielectric laminate having relative permittivity  $\epsilon_r = 3.78$ , and loss tangent  $\tan\delta = 0.025$ , the thickness of the metal layers being

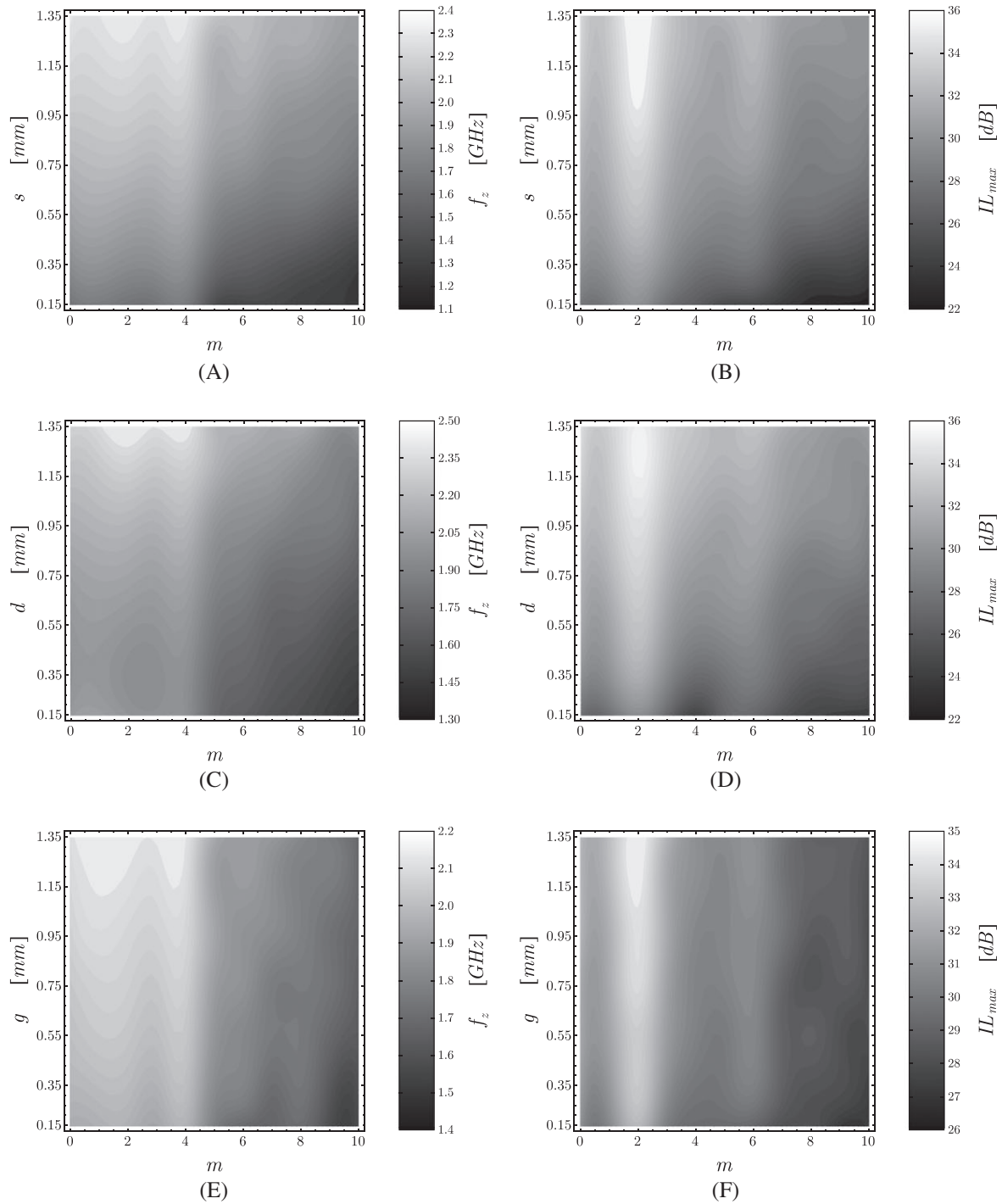

**FIGURE 3** Stop-band frequency  $f_z$  and peak insertion loss  $IL_{max}$  of supershaped complementary split ring resonators-based filters as a function of the Gielis parameter  $m$  and the geometrical parameters  $s$ ,  $d$ ,  $g$  as shown in Figure 2

$t = 35 \mu\text{m}$ . The two concentric ring slots forming the CSRR unit are separated by distance  $s$ , and are characterized by width  $d$  and gap  $g$ . Conversely, the microstrip line printed on the circuit substrate features a width  $w = 1.835 \text{ mm}$ , which is selected in such a way as to achieve a nearly  $50 \Omega$  characteristic impedance.

The design and full-wave analysis of the complete assembly has been carried out by making use of the commercially available electromagnetic solver *CST Microwave Studio*.<sup>14</sup> In this way, the characteristics of the structure in

terms of stop-band frequency  $f_z$  and peak insertion loss ( $IL_{max} = -20 \log |S_{21}(f_z)|$ ) have been evaluated as a function of the geometrical parameters  $s$ ,  $d$ ,  $g$ , and  $m$ .

From the visual inspection of Figure 3, it is apparent that  $f_z$  is decreasing as  $s$ ,  $d$ ,  $g$  become smaller, and the Gielis order  $m$  increases. Conversely, under the same conditions,  $IL_{max}$  tends to decrease. It is worth noting here that the general supershaped CSRR as described by (1) degenerates in the conventional circular and square one for  $m \rightarrow 0$  and  $m = 4$ , respectively.

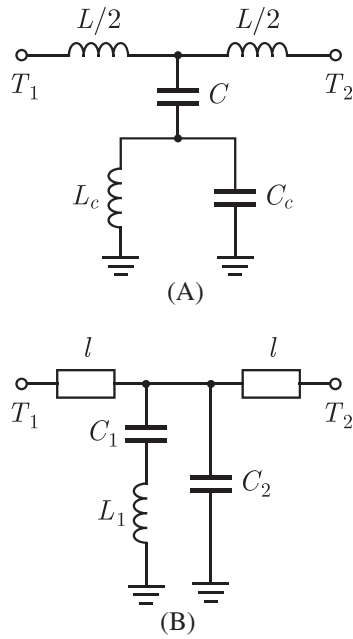
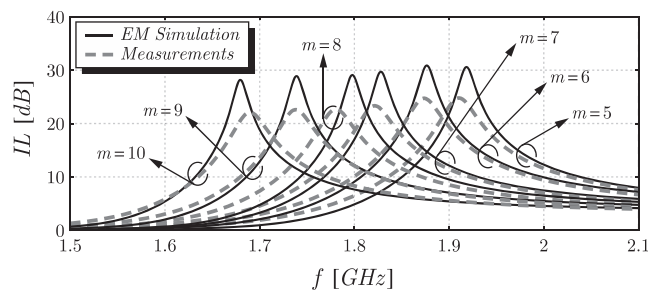

**FIGURE 4** Lumped-element equivalent circuit models of a complementary split ring resonators-loaded microstrip line (see Figure 2) as proposed by Baena et al. (A) and Li et al. (B)

Following the design stage, several physical demonstrators of the considered filtering structures (see Figure 2A), with  $s = d = g = 0.75$  mm and  $m$  ranging from 5 to 10, have been fabricated. As it can be noticed in Figure 2B, SMA adapters are soldered at both ports of the device, and adopted as connector interface to external coaxial cables for  $S$ -parameter measurements.

### 2.3 | Equivalent circuit models

Thanks to the small electrical size of CSRRs at the resonance ( $\sim \lambda/10$ ), the considered structures can be conveniently described by means of suitable lumped-element equivalent circuits. Several models have been proposed in the scientific literature. In this respect, Baena et al. proposed the circuit topology shown in Figure 4A,<sup>6</sup> where the CSRR unit is modeled as a parallel resonant tank with inductance  $L_c$  and capacitance  $C_c$  and, therefore, characterized by resonant frequency:



**FIGURE 5** Insertion loss of a microstrip transmission line loaded with a supershaped complementary split ring resonators of Gielis order  $m \in [5, 10]$

**TABLE 1** Equivalent circuit parameters of supershaped complementary split ring resonators as a function of the relevant Gielis order  $m$  ( $C_x$  in pF,  $L_x$  in nH)

$m$	$L$	$C$	$L_c$	$C_c$	$L_1$	$C_1$	$C_2$
5	3.85	0.95	5.59	0.27	8.31	0.83	-2.51
6	3.54	1.06	5.62	0.22	7.98	0.90	-2.51
7	4.18	0.91	6.38	0.28	9.44	0.80	-2.51
8	4.33	0.87	6.70	0.30	10.28	0.76	-2.53
9	4.45	0.89	6.98	0.31	10.35	0.81	-2.63
10	4.37	0.86	7.92	0.27	11.58	0.78	-2.59

$$f_0 = \frac{1}{2\pi\sqrt{L_c C_c}}. \quad (5)$$

In said schematic, the capacitance  $C$  models the coupling between the CSRR and the microstrip line which, in turn, is characterized by inductance  $L$ . It is worth mentioning that the inductance  $L_c$  is mainly dependent on the length  $\ell_m$  of the CSRR embedded in the design, whereas the capacitance  $C$  is largely affected by the relevant area which, for the proposed class of structures, is an invariant.

At frequency  $f_0$ , the shunt admittance is zero and, therefore, the impedance measured at the any port of the network is set by the host line inductance  $L$  which, in turn, can be readily estimated by using well-known computer-aided design (CAD) formulas available in the scientific literature. Conversely, the transmission-zero frequency of the filter, at which the condition  $S_{21} = 0$  holds true, is readily found to be:

$$f_z = \frac{1}{2\pi\sqrt{L_c(C + C_c)}}. \quad (6)$$

Finally, upon denoting the series and shunt impedances of the equivalent T-network of the structure as  $Z_1$  and  $Z_2$ , respectively, one can verify, after simple mathematical manipulations, that:

$$Z_1(f_{\pi/2}) + Z_2(f_{\pi/2}) = 0, \quad (7)$$

with  $f_{\pi/2}$  being the frequency where the phase of the transmission coefficient  $S_{21}$  is equal to zero. By combining (5) and (6) with (7), the parameters of the circuit model in Figure 4A can be extracted from the numerically simulated  $S$ -parameter data.

Li et al. proposed, for the considered structure, the alternative equivalent circuit topology shown in Figure 4B,<sup>7</sup> that consists of a series  $LC$  resonator ( $L_1, C_1$ ) with a capacitance  $C_2$  connected in parallel, as well as two sections of  $50 \Omega$  transmission lines having length  $l$  at both sides. This model is characterized by a higher degree of accuracy over a broader frequency band of operation, though it relies on a negative-value parameter as outlined hereinafter.

Three independent equations are needed for the synthesis of the circuit in Figure 4B. The first one is given by the resonant condition of the whole shunt branch of the equivalent T-network that reflects in the zero of the input reflection

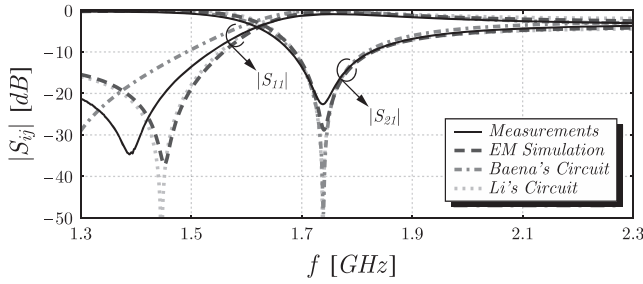

**FIGURE 6** Magnitude of the scattering parameters of the supershaped complementary split ring resonator of order  $m = 9$  as simulated numerically, measured on a physical prototype, and evaluated by using the equivalent circuits in Figure 4

coefficient  $S_{11}$  at frequency  $f_1$ . The second equation is related to the resonance condition of the series  $LC$  tank ( $L_1$ ,  $C_1$ ), that corresponds to the zero of the transmission coefficient  $S_{21}$  at frequency  $f_2$ . The third condition is derived by enforcing the 3 dB insertion loss level at frequency  $f_3$ . In this way, one can verify that<sup>7</sup>:

$$C_2 = \frac{Y_0 f_2^2 - f_3^2}{\pi f_3 f_1^2 - f_3^2}, \quad (8)$$

$$C_1 = \left[ \left( \frac{f_1}{f_2} \right)^2 - 1 \right] C_1, \quad (9)$$

$$L_1 = \frac{1}{(2\pi f_2)^2 C_1}, \quad (10)$$

where  $Y_0$  is the characteristic admittance of the input lines. It is apparent from (10) that the  $C_2$  is negative as  $f_1 < f_3 < f_2$ . Finally, the length  $l$  of the microstrip line sections embedded in the series branches of the equivalent circuit is determined by fitting the phase of the scattering parameters.

As it appears in Figure 4, the considered equivalent circuit networks do not account for loss mechanisms occurring in the corresponding physical structure. However, this non-ideality can be easily addressed by integrating resistive elements in the resonant  $LC$  tanks included in both models.

### 3 | NUMERICAL RESULTS AND MEASUREMENTS

Following the procedure described in section 2, equivalent circuit models of the considered supershaped CSRR filters have been extracted starting from the numerical simulation data. The circuit parameters are given in Table 1 as a

**TABLE 2** Transmission-zero frequency of supershaped complementary split ring resonators as a function of the relevant Gielis order  $m$  ( $f_z$  in GHz)

$m$	5	6	7	8	9	10
$f_z$ (EM simulation)	1.918	1.877	1.827	1.798	1.738	1.679
$f_z$ (measurements)	1.910	1.850	1.820	1.780	1.740	1.690

function of the Gielis order  $m$ . It is worth noting that, in Baena's model, the inductance  $L_c$  increases with the length of the CSRR, whereas the capacitance  $C_c$  is nearly constant with a slow variation around the average value of about 0.275 pF. As for Li's model, one can notice that the equivalent capacitance  $C_2$  is negative, though that can be easily offset by using the same approach suggested in Ref. 7

Figure 5 shows the simulated and measured insertion loss versus frequency of the designed structures for different values of the order  $m$ . As it appears from Table 2, the transmission-zero frequency  $f_z$  of the considered class of CSRRs decreases, with a nearly linear progression, as  $m$  becomes larger. A good agreement between numerical and experimental results can be noticed in Figure 5 and Table 2. However, from the visual inspection of Figure 5, it is apparent that a deviation occurs in terms of simulated and measured insertion-loss bandwidth, this being attributable to a mismatch between the actual loss tangent featured by the dielectric laminate used for the manufacturing of the filter prototypes (see Figure 2B) and the nominal value adopted in the numerically based electromagnetic model of the various structures.

As an example, Figure 6 shows the frequency-domain behavior of the magnitude of the coupling coefficient  $|S_{21}|$  and input reflection coefficient  $|S_{11}|$  of the supershaped CSRR of order  $m = 9$ , as simulated with *CST Microwave Studio*, measured on physical prototypes, and evaluated using the equivalent circuits shown in Figure 4. The agreement between numerical and experimental results is pretty good, minor discrepancies in return loss being attributed to tolerances in the fabrication process and parasitic effects associated with the microstrip-line-connector transition which is responsible for an unwanted impedance deviation.

As for the equivalent circuits, both proposed models can predict the stop-band behavior of supershaped CSRRs with a reasonable accuracy, though Li's equivalent circuit shows a better agreement with simulated data across a broader range of frequencies, this being beneficial for a more effective design process of microwave systems by means of CAD software applications. This is however achieved at the expense of a higher complexity level associated with the integration of microstrip line sections and, possibly, a negative capacitor (see Table 1) in the network. Conversely, Baena's circuit provides a useful physical insight in terms of the equivalent intrinsic inductance and capacitance of CSRRs.

### 4 | CONCLUSIONS

A new class of supershaped CSRR filters has been presented, and the relevant circuital behavior studied extensively. It has been demonstrated that the transmission-zero frequency of the considered structures can be easily tuned by properly selecting their Gielis order, while keeping other characteristics nearly unchanged. Novel designs based on the periodic or

aperiodic clustering of supershaped CSRRs are being investigated to synthesize high-performance filter structures.

#### ACKNOWLEDGMENT

This study has been carried out in the framework of the research and development program at The Antenna Company, and is funded by the Competitiveness Enhancement Program grant at Tomsk Polytechnic University, Russia, with the support of the National University of Science and Technology MISiS and the Junta de Andalucía (Spain) under the contract P12-TIC-1442. For information, please visit the web site <http://www.antennacompany.com/>.

#### ORCID

Diego Caratelli  <https://orcid.org/0000-0003-0969-884X>

#### REFERENCES

1. Veselago VG. The electrodynamics of substances with simultaneous negative values of  $\epsilon$  and  $\mu$ . *Soviet Phys Uspekhi*. 1968;10(4):509-514.
2. Pendry JB. Negative refraction makes perfect lens. *Phys Rev Lett*. 2000; 85(18):3966-3969.
3. Ziolkowski RW. Design, fabrication, and testing of double negative metamaterials. *IEEE Trans Antennas Propag*. 2003;51(7):1516-1529.
4. Falcone F, Lopetegi T, Baena JD, Marques R, Martín F, Sorolla M. Effective negative- $\epsilon$  stopband microstrip lines based on complementary split ring resonators. *IEEE Microw Compon Lett*. 2004;14(6):280-282.
5. Qiang L, Zhao Y-J, Sun Q, Zhao W, Liu B. A compact UWB HMSIW bandpass filter based on complementary split-ring resonators. *Prog Electromagn Res C*. 2009;11:237-243.
6. Baena JD, Bonache J, Martín F, et al. Equivalent-circuit model for split-ring resonators and complementary split-ring resonators coupled to planar transmission lines. *IEEE Trans Microw Theory Tech*. 2005;53(4):1451-1461.
7. Li C, Liu KY, Li F. A microstrip highpass filter with complementary split ring resonators. *Prog Electromagn Res Symp*. 2007;3(5):583-586.
8. Lai X, Li Q, Qin P-Y, Wu B, Liang C-H. A novel wideband bandpass filter based on complementary split-ring resonator. *Prog Electromagn Res C*. 2008;1:177-184.
9. Durán-Sindreu M, Vélez A, Aznar F, Sisó G, Bonache J, Martín F. Applications of open split ring resonators and open complementary split ring resonators to the synthesis of artificial transmission lines and microwave passive components. *IEEE Trans Microw Theory Tech*. 2009;57(12):3395-3403.
10. Khan SN, Liu X, Shao L, Wang Y. Complementary split ring resonators of large stop bandwidth. *Prog Electromagn Res Lett*. 2010;14:127-132.
11. Marqués R, Martín F, Sorolla M. *Metamaterials with Negative Parameters: Theory, Design, and Microwave Applications*. New York: Wiley; 2011.
12. Crnojevic-Bengin V, Radonic V, Jokanovic B. Fractal geometries of complementary split-ring resonators. *IEEE Trans Microw Theory Tech*. 2008; 56(10):2312-2321.
13. Gielis J. A generic geometric transformation that unifies a wide range of natural and abstract shapes. *Am J Botany*. 2004;90(3):333-338.
14. CST Computer Simulation Technology, Retrieved from <http://www.cst.com/>

#### AUTHOR BIOGRAPHIES



**ENRIQUE J. RUBIO MARTÍNEZ-DUEÑAS** received the Bachelor Degree in Telecommunications Engineering in Sound and Image from the University of Malaga in 2013 and the Master Degree in Telecommunications from the European University of Madrid, Spain

in 2016. He worked as a Technical Support Researcher for the University of Granada (Spain) from October 2014 to December 2016, participating in several research project related to Numerical Techniques for Electromagnetic Compatibility problems and to Ground Penetrating Radar scenarios and was a visiting researcher at The Antenna Company, The Netherlands, from September to December 2016. He is currently working for Vodafone Global, Madrid, Spain, as Service Manager.



**CARLOS MORENO DE JONG VAN COEVORDEN** received his PhD degree in physics from the University of Granada, Spain, in 2008. He worked from 2001 to 2015 with the Electromagnetic Group at the Department of Electromagnetism, University of Granada,

Spain, first as a research assistant in several national and international projects with public and private funding and, from 2009 to 2015, as an assistant professor; he qualified for associate professor in 2013. He has received grants to be a visiting scholar at the University of Pisa (2005), the University of Stellenbosch (2009 and 2010), and the University of Belo Horizonte (2012). His research interests include computational electromagnetics, antenna design and measurement, application of optimization methods to antenna design and geometry, application of Gielis transformations to antenna design and optimization methods, and remote sensing. Since 2015, he is working at The Antenna Company, The Netherlands, as Staff Antenna Engineer.



**OLEG V. STUKACH** received the Diploma degree in radio engineering (with honors) in 1988 and the Doctor of Technical Sciences degree in modeling, numerical methods, and software in 2010 from Tomsk State University of Control Systems and Radio-

electronics, Tomsk, Russia. In 1988, he joined the Picosecond Technique Labs, Tomsk, Russia. Currently, he is Professor of National Research University "Higher School of Economics", HSE Tikhonov Moscow Institute of Electronics and Mathematics (MIEM HSE), Moscow, Russia. He has published more than 250 technical papers and patents in the fields of microwave technique, ground penetrating radar (GPR), and theory of control. His principal area of specialization includes theory of parametric invariance of nonlinear systems.

Since 1995, Dr. Stukach serves as Chair of the biennial International Siberian Conference on Control and Communications (SIBCON), and Moscow Workshop on Electronic and Networking Technologies (MWENT). He is organizer and active participant of international

scientific conferences, winner of the Tomsk Region Prize in science and education.



**NIKOLAY V. PANOKIN** received the Diploma degree in radio engineering in 1980 from Moscow Institute of Physics and Technology (MIPT) and PhD degree in electrodynamics theory and adaptive signal processing in phased arrays in 1985. Since 2012, he has been a Head of Science Department in National University of Science and Technology MISiS, Moscow, Russia. His area of specialization and research interests include neural and intelligent signal processing, machine learning, pattern recognition, and radar imaging technology.



**JOHAN GIELIS** received the degree of engineering in Biosciences in 1985. From 1986 up to 2012, he worked in the field of plant biotechnology. Following his PhD in 2010, he became visiting professor at the Department of Bioscience Engineering, University of Antwerp, and has been guest lecturer at over 20 universities. The discovery of what now has become known in mathematics as Gielis formula, Gielis curves and surfaces, or Gielis Transformations in more general terms, has led to over 100 different technological applications worldwide. He is coauthor of over 50 peer reviewed papers and books, and holds over 20 patents. Since 2013, Prof Gielis is involved, together with Diego Caratelli, in The Antenna Company. Within the Antenna Company, he is responsible for production methods, planning and product quality, and heads the research for novel materials for antennas. His entrepreneurial activities extended into companies focusing on game technology and additive manufacturing.



**DIEGO CARATELLI** received the Laurea (*summa cum laude*) and PhD degrees in Electronic Engineering, as well the MSc degree (*summa cum laude*) in Applied Mathematics from Sapienza University of Rome in 2000, 2004, and 2013, respectively. In 2013, he has co-founded The Antenna Company, where is currently Chief Technology Officer. At the Antenna Company, he is responsible for product development, as well as for program portfolio management and coordination of the engineering team. He is, also, associate professor at Tomsk Polytechnic University and Visiting Researcher at Eindhoven University of Technology. His research activity has so far resulted in 170 publications in peer-reviewed journals, book chapters, and conference proceedings. He holds 10 families of patents in antenna technologies, and advanced computational techniques. Dr Caratelli was the recipient of the Young Antenna Engineer Prize at the 32th ESA Antenna Workshop. He received the 2010 Best Paper Award from Applied Computational Electromagnetics Society. He was co-recipient of the Frost&Sullivan Best Practices Award for technology innovation in advanced antennas for wireless communications in 2016.

**How to cite this article:** Rubio Martínez-Dueñas EJ, Moreno de Jong van Coevorden C, Stukach OV, Panokin NV, Gielis J, Caratelli D. Electromagnetic modeling and design of a novel class of complementary split-ring resonators. *Int J RF Microw Comput Aided Eng.* 2018;e21582. <https://doi.org/10.1002/mmce.21582>