

**This item is the archived peer-reviewed author-version of:**

Prospects of solar systems in production chain of sunflower oil using cold press method with concentrating energy and life cycle assessment

**Reference:**

Nabavi-Pelesaraei Ashkan, Azadi Hossein, Van Passel Steven, Saber Zahra, Hosseini-Fashami Fatemeh, Mostashari-Rad Fatemeh, Ghasemi-Mobtaker Hassan.- Prospects of solar systems in production chain of sunflower oil using cold press method with concentrating energy and life cycle assessment  
Energy: the international journal - ISSN 0360-5442 - 223(2021), 120117  
Full text (Publisher's DOI): <https://doi.org/10.1016/J.ENERGY.2021.120117>  
To cite this reference: <https://hdl.handle.net/10067/1781930151162165141>

# Prospects of solar systems in production chain of sunflower oil using cold press method with concentrating energy and life cycle assessment

## Authors:

Ashkan Nabavi-Pelesaraei <sup>a, b, \*, 1, 2, 3</sup>, Hossein Azadi <sup>c, \*</sup>, Steven Van Passel <sup>d</sup>, Zahra Saber <sup>e</sup>, Fatemeh Hosseini-Fashami <sup>a</sup>, Fatemeh Mostashari-Rad <sup>f</sup>, Hassan Ghasemi-Mobtaker <sup>a, \*</sup>

## Affiliation:

<sup>a</sup> Department of Agricultural Machinery Engineering, Faculty of Agricultural Engineering and Technology, University of Tehran, Karaj, Iran

<sup>b</sup> Head of Process Engineering & Systems Improvement, Management of Fruit and Vegetables Organizations, Tehran Municipality, Tehran, Iran

<sup>c</sup> Department of Geography, Ghent University, Ghent, Belgium

<sup>d</sup> Department of Engineering Management, University of Antwerp, Belgium

<sup>e</sup> Department of Agronomy and Plant Breeding, Sari Agricultural Sciences and Natural Resources University, Sari, Iran

<sup>f</sup> Department of Agricultural Biotechnology, Faculty of Agricultural Sciences, University of Guilan, Rasht, Iran

<sup>1</sup> [https://www.researchgate.net/profile/Ashkan\\_Nabavi-Pelesaraei](https://www.researchgate.net/profile/Ashkan_Nabavi-Pelesaraei)

<sup>2</sup> <https://scholar.google.com/citations?user=JQNGIIIAAA&hl=en>

<sup>3</sup> <http://orcid.org/0000-0003-2823-6616>

\* **Corresponding authors:** Ashkan Nabavi-Pelesaraei ([ashkan.nabavi@ut.ac.ir](mailto:ashkan.nabavi@ut.ac.ir))

Hossein Azadi ([s\\_hossein.azadi@ugent.be](mailto:s_hossein.azadi@ugent.be))

Hassan Ghasemi-Mobtaker ([mobtaker@ut.ac.ir](mailto:mobtaker@ut.ac.ir))

### **Complete Postal Addresses:**

Department of Agricultural Machinery Engineering, Faculty of Agricultural Engineering and Technology, University of Tehran, Karaj, Iran

Department of Geography, Ghent University, Ghent, Belgium

## **Prospects of solar systems in production chain of sunflower oil using cold press method with concentrating energy and life cycle assessment**

### **Abstract**

The aim of this study is determination of exergoenvironmental efficiency for using solar technologies in sunflower oil production in Iran. Accordingly, the applications of photovoltaic and photovoltaic/thermal systems were evaluated for both agricultural and industrial phases of sunflower oil production. Energy results reveal that 1 ton of sunflower oil consumes and produces about 180354 and 39400 MJ energy, respectively. About 86% of total energy consumption belongs to agricultural phase and electricity with 32%, has the highest share of total energy consumption. IMPACT 2002+ method and cumulative energy demand of life cycle assessment are applied to 3 defined scenarios including Present, photovoltaic and photovoltaic/thermal. Results indicate that total amounts of climate change in Present scenarios is 24537.53 kg CO<sub>2</sub> eq.. The highest share of human health (90%), ecosystem quality (90%) and climate change (50%) in all scenarios belongs to direct emissions. Results also illustrates that

total cumulative energy demand of Present, photovoltaic and photovoltaic/thermal scenarios are about 177538, 99054 and 132158 MJ 1TSO<sup>-1</sup>, respectively. Furthermore, the most contribution of non-renewable resources and fossil fuels belongs to electricity (37%), nitrogen (52%) and photovoltaic/thermal panels (39%) in Present, photovoltaic and photovoltaic/thermal scenarios, respectively. Finally the photovoltaic scenario is the best environmental-friendly scenario.

**Keywords:** Cumulative energy demand; IMPACT 2002+; Life cycle assessment; Photovoltaic; Sunflower oil

<b>Nomenclature</b>	
°C	Celsius degree
1TSO	1 ton of sunflower oil
C <sub>6</sub> H <sub>6</sub>	Benzene
Cd	Cadmium
CED	Cumulative energy demand
CH <sub>4</sub>	Methane
CF	Carbon footprint
CO	Carbon monoxide
CO <sub>2</sub>	Carbon dioxide
Cr	Chromium
Cu	Copper
DALY	Disability adjusted life years
FU	Functional unit

GHG	Greenhouse gas
h	Hour
ha	Hectare
Hg	Mercury
IEA	International Energy Agency
kg	Kilogram
kg CO <sub>2</sub> eq.	Kilogram of carbon dioxide equivalent
kWh	Kilowatt hour
L	Liter
LCA	Life cycle assessment
LCI	Life cycle inventory
LCIA	Life cycle impact assessment
mg	Milligram
MJ	Mega joule
MWh	Megawatt hour
N <sub>2</sub> O	Dinitrogen monoxide
NH <sub>3</sub>	Ammonia
Ni	Nickel
NMVOG	Non-methane volatile organic compound
NO <sub>3</sub> <sup>-</sup>	Nitrate
NO <sub>x</sub>	Nitrogen oxides
PAH	Polycyclic aromatic hydrocarbon
Pb	Lead
PDF*m <sup>2</sup> *yr <sup>b</sup>	Potentially disappeared fraction
PO <sub>4</sub> <sup>3-</sup>	Phosphate
PV	Photovoltaic
PV/T	Photovoltaic/thermal
Se	Selenium
SEIA	Solar Energy Industries Association
SO <sub>2</sub>	Sulfur dioxide
SOP	Sunflower oil production
t	Ton

t.km	Ton in kilometer
TRNSYS	The Transient System Simulation
Zn	Zinc

## 1. Introduction

Due to enhancement of life quality, industrial improvement in developing nations and the enormous expansion in world population, fossil fuel use has been enormously elevated. Improper use of fossil fuels causes depletion of non-renewable resources and aggravation of environmental hazards simultaneously, which have negative impacts on human healthfulness and ecological systems [1]. Energy derived from crop production is one of the major potential energy resources for future energy needs worldwide. In this regard, the literature on biofuels production by energy crops reveals that they are very environmentally and economically viable in sustainable energy production [2–4]. Several crops such as soybeans, sugar beets, corn, wheat, rapeseed, and sunflowers are now being exploited in most developed countries to access energy [3]. Among all oil seed, sunflower is a remarkable oilseed crop and, because of its great oil content, is used for biodiesel production and household consumption [5,6]. Sunflower belongs to *Asteraceae* or *Compositae* family and is an important oilseed [7,8]. It is used in eatable oil production and its yearly production is about 25.1 million tons. The compound of linoleic, oleic, and linoleic acids in sunflower oil affects oxidative constancy. The content of linoleic acid in sunflower oil is nearly 70% and is very sensitive to lipid oxidation [9,10]. In

recent decades, the industrial process of extracting oil has not been modified considerably; however, several practical improvements in optimization and better control have been noticed [11]. An ordinary method in extracting sunflower oil includes preparation of seed and mechanical extraction [12]. Since no type of solvent and no other processing are involved in the production of cold-pressed oil, rather than filtering and pressing, it is more important for the market. Oils that are generated by mechanical processes such as pressing or expelling without the use of heat, as well as any changes in the oil, are cold-pressed oils, based on Codex Alimentarius Standard for Named Vegetable Oils. Cold-pressed oils are considered an appealing choice because consumers prefer minimally processed foods free of synthetic preservatives. Furthermore, biologically active compounds can be preserved throughout the processing in cold-pressed oil [13].

On the other hand, agri-food sector is considered the main energy consumer of most countries. Energy consumption is one of the most expensive inputs for farming crops and related industries [14]. The dependence between the energy source kind and agri-food systems is very close [15], moreover type of used energy and status and quality of environmental are mutually dependent [16]. Therefore, to reduce dependence on non-renewable energy sources and maintain the quality of the environment, energy efficiency in agriculture needs to be improved [17]. A type of energy that is generated from renewable sources and can be replaced by a natural process in the form of energy produced by sun or wind is renewable energy. It is quickly

developing as an alternative to fossil fuels throughout the world [18]. Among renewable energy resources, solar technology has a great role in providing renewable energy. Considering the geographical location of Iran and being in solar belt of world, solar energy is one of the important options among the available alternative renewable energy sources with multiple applications in different industries [19]. Various benefits over fossil fuels include more energy supply diversification, diminished carbon dioxide emissions, and regional/national energy independence [20]. By 2050, solar energy will have the potential to be the world's largest source of electricity, based on IEA [21]. The solar photovoltaic (PV) system, with its independent operation and less environmental impact, is a powerful source for off-grid systems [22]. Due to economic and environmental benefits, PV has attracted the attention of many manufacturers, decision-makers, and researchers as a source of clean power generation [23]. Because of the lack of a deep understanding of its potential, PV technology has not yet been completely appreciated in many areas [24]. Currently, the efficiency of converting solar radiation in PV panels to electricity is in the range of 12% to 18%, and more than 80% of solar radiation is either converted to heat or reflected [25]. As a matter of fact, enhancing the temperature of the PV panel decreases its efficiency so that a 10 °C increase leads to a 5% decrease in PV panel efficiency [23]. Many researchers have recommended the use of cooling fluids such as water and air to reduce the temperature from the PV panel which is called a hybrid photovoltaic/thermal (PV/T) solar collector [26–28]. In this case, this system will be able to



heat water, air, or both at the same time and also increase the electricity generated by the PV panel. The efficiency of the PV panel basically depends on the solar temperature and radiation if the PV/T consists of the thermal and electrical efficiencies of the PV panel. Electrical efficiency represents the percentage of advantages taken by the system from solar radiation to generate electricity over a specific period, while thermal efficiency mainly involves a useful thermal profit ratio [23].

Climate change, as a result of enhancing energy consumption, and environmental damages emissions of agricultural activities have become major concerns around the world [29]. Agriculture accounts for 10–12% of the total GHG emissions each year [30]. Based on ISO [31], a product's life cycle is defined as “successive and interconnect steps of a production system, from crude substance attainment or production from natural resources to final access”. Life cycle assessment (LCA) is a technique that is used for evaluating different aspects of environmental and potential impacts affiliated with a production process. LCA checks out different aspects of potential environmental impacts throughout the whole life cycle of a product (i.e., cradle-to-grave) from crude substance attainment via production, usage, and access [32]. In particular, LCA is known extensively as a quantitative tool to assess environmental impacts of products, procedures, or services through computing energy/substance inputs and wastes generated to the environment, and by evaluating potential environmental impacts of those energy resources, substances, and wastes [33].

The cumulative energy demand (CED), also named ‘primary energy consumption’, has been one of the main indicators being considered in the LCA studies [34]. As an indicator of the primary energy embodied in the service or product, CED is estimated as the amount of primary energy that should be consumed for the production, use, and disposal phase. CED can be fully an advantageous tool to calculate the environmental impacts of the service or product since many environmental impacts are related to it [35]. In fact, CED clarifies the whole demand, valued as primary energy, which arises in relation to the production, consumption, and disposal of an economic commodity. Therefore, it is considered as an environmental impact indicator that relates to the energetic performance of power systems based upon their whole life cycle [36].

There are many studies investigating the application of energy, LCA, and solar technologies in agricultural products. Table 1 sums up a diversity of them carried out in agri-food sector from agriculture feed stocks and environmental aspects of processing of products for achieving final products.

### **Table 1**

It can be observed from Table 1 that while some works have been performed in this respect, the significance of this topic lies in the lack of comprehensive investigations from farm to final product. Moreover, applying solar systems did not survey from environmental aspects. As such, the main aim of this research is to take a novel approach by including the designation of

environmental impacts and efficiency from sunflower farm to in sunflower oil production (SOP) with simulation of solar systems. Moreover, this research considered two fuzz models including farming system of sunflower production and industrial system of oil extraction, while in most studies only one aspect has been examined by researchers. It should be noted that there is no research about the LCA of solar technology usage in vegetable oil extraction that has not been investigated in this study. According to the above-mentioned explanation, the following specific objectives were determined for this research:

- Determination of the pattern of energy use in sunflower production and oil extraction process
- Simulating PV and PV/T solar systems to supply clean energy as an alternative in sunflower production and oil extraction process
- Evaluation of environmental damages and CED for defined scenarios
- Selection of best scenarios by considering energy-environmental aspects
- Sensitivity analysis of effective inputs in defined scenarios of SOP
- Proposal of early and late return strategies for each scenario with a future prospect

## **2. Materials and methods**

### *2.1. Case study and data acquisition*

This research is accomplished in West Azerbaijan province, the most important center of sunflower production in Iran. West Azerbaijan is located in the northwest of Iran, at the 44°

03' and 47° 23' east longitude and 35° 58' and 39° 46' north latitude [65]. The location of this province in Iran is shown in Fig. 1.

**Fig. 1**

Preparation of farms is the first stage in sunflower production. To reach this goal, plough proceedings are carried out in two steps to get the finest soil features for the harvest system. Tractor is used for the primitive plough, but for the secondary plough proceedings, disk harrow, cultivator, and leveler equipment are used. Due to climate conditions of the region, sunflower is commonly planted in spring through mid-April to early June. The date for sowing is from 5 to 20 May in the case study regions. Various combinations of biocides are used in farms to control weeds and diseases in practical procedure. The harvesting time of sunflower has a similar condition with sowing and, due to the climatic conditions of the region, sunflower production is from 3 to 5 months after sowing. The harvesting date in West Azerbaijan province is from 5 to 20 September [65].

In the current research, various input and output data are required for different analyses. Therefore, the primary data are assembled from some manufacturers in the 2019 production period and their outputs are used for oil extraction. In this connection, a questionnaire is arranged with a typical example shown in Table 2.

**Table 2**

In the current research, an automatic oil press machine is applied for mechanical extraction in order to reduce costs for small scale work. The machine is bought from Iran Cold-Pressing Company and the model is ICP-65 mm with a capacity of 300 kg/24 h, electrical power of 1.5 kWh (1&3 phase), and weight of 180 kg as shown in Fig. 2.

**Fig. 2**

### *2.2. Energy use pattern of SOP*

The energy analysis of SOP is divided into two sections, including agricultural and industrial phases. In the first section, the physical amounts of all inputs, from planting to harvesting steps, and in the second section, the rates of all inputs related to transferring sunflower seed and extracting oil were determined and multiplied by the standard coefficient of energy contents that are shown in Table 3. In addition, the sunflower oil is considered as an output in the study. In the studied area, the residue of sunflower oil is disposed of. Therefore, the energetic value is not considered in this research.

**Table 3**

### *2.3. Layout and design method of solar systems*

The solar technologies for supplying energy in agri-food sector are well known and they have recently converged to the few types used today. The important element of these systems is the establishment of solar systems such as PV and PV/T to collect and convert solar radiation to usable energy [81]. PV is applied to convert sunlight energy into electrical DC energy. In this

regard, the solar cell is actually the smallest unit, and these cells are connected in parallel and series to generate a PV module. Furthermore, in order to produce PV arrays, PV modules are connected in parallel and series [23]. As mentioned above, a PV/T system is a combination of solar thermal and PV components and produces heat and electricity from a combined system [82]. It consists of conventional thermal collectors as well as an absorber covered by a PV layer [83]. The PV modules generate electricity accompanied by the absorbed thermal energy that is simultaneously transported away by the working fluids. The space applications of PV/T collectors are higher compared to those of thermal collectors and conventional PV systems. The area covered with PV/T collectors can supply more heat and electricity than the area covered with conventional thermal collectors and conventional PV systems, separately. It is also significantly useful when the space is limited and will be more useful in the future [84].

Energy efficiency of SOP as a resource for biodiesel production is very important because the value of alternative fuel is determined by the energy balance between production and consumption of them. In Iran, most of the energy (about 80%), such as electricity, is produced by combustion of fossil fuels in the electrical generators of power plants [85]. This makes the use of biofuel energy resource unjustified. Therefore, revision of energy use systems in SOP is a vital priority. These revisions include both industrial and agricultural phases of sunflower production. Accordingly, in this research, the potential of application of PV and PV/T systems is determined for supplying energy. In the first step, the energy inputs can be replaced by the

mentioned systems. With respect to the input energy list of SOP, diesel fuel is the fossil resources that should be exchanged for the electricity produced by solar systems. Of course, in solar systems, the obtained energy is based on electricity. So, in the next step, the energy requirement is examined as electrical power. Regarding the electricity input, direct use is considered for solar systems, but diesel fuel energy should be converted to electricity. Accordingly, the calculated energy of diesel fuel use is converted to electricity by the standard coefficient of Table 3. Then its rate is added to electricity. Finally, the amount of electricity requirement is calculated for use in solar systems. There are several simulating methods for establishment of solar systems. Among all, TRNSYS is almost a new approach used by many researchers [86]. TRNSYS is an abbreviation formed for a “transient simulation program” and is a quasi-steady simulation model, developed by the members of the Solar Energy Laboratory of Wisconsin University [87]. In TRNSYS simulation, constructing an information flow diagram is necessary for a system whose purpose is to facilitate the identification of the flow and components of the information between them. An information flow diagram shows the way all components of the system are interconnected. In this respect, each component is shown as a box requiring time-dependent inputs and certain constant parameters producing a time-dependent output. Any number of other components may be applied as an input to a given output. Fig. 3 shows a simplified data flow diagram for Solar PV and PV/T systems.

**Fig. 3**

The main PV and PV/T panels constructed for this purpose are type 94a and type 50b, respectively, based on Fig. 3. In this study, the Sharp Solar Panel Model ND-AH325, 325 W is applied for determination of the panel area, the number of panels, and the panel closure in both PV/T and PV systems. Additional components required are type 64 and type 65d of the library, and finally, type 25c library is selected as a printer.

In order to predict the performance in computer simulations, it is crucial to choose the typical weather conditions for a given location that has led investigators either to choose a specific year or to run long periods of observational data, which seems to be typical for several years of data. Petrakis et al. [88] have constructed the TMY by hourly measurements of solar irradiance for a 7-year period (diffuse and global on a horizontal surface), from 1986 to 1992. Klein et al. [89] have generated the “average year” by choosing the monthly data from an 8-year period which corresponded most closely to that of the average monthly ambient and insolation temperature. Therefore, in this study, type 109 tmy2 is selected for uploading meteorological data of West Azerbaijan province, Iran, and the summary of them is shown in Table 4. The required information such as reflective and direct solar energy, along with the amount of cloudy and sunshine hours, and therefore the whole sun energy received, was extracted by Meteonorm software in TMY2 format for a 10-year period. Panels’ slope surface is a crucial point in TRNSYS simulation. Actually, the slope of surface can be effective in the



efficiency of both PV and PV/T systems. In the final part of the complete designed circulate, the temperature of water used for PV/T systems is entered in TRNSYS simulation.

#### **Table 4**

#### *2.4. LCA method*

LCA is a method that is utilized to assess likely environmental impacts and a product's resources, services, or processes all over the lifetime, from crude substance attainment, generation, and steps to various production systems [31,62,90,91]. It is a standardized method for supplying a scientific foundation of environmental sustainability for government and industry [92,93]. LCA evaluates environmental effects relevant to the recyclability of composed substances [94–96]. By applying LCA method, environmental effects at every step of the cradle-to-gate of the life cycle, from the generation of the crude substance, containing every related production, shipment, utilization of the user and the access of post-use waste are analyzed completely [104, 105]. There are four steps in LCA, including outlining the scope and purpose, inventory analysis, impact assessment, and finally, interoperation of life cycle [31]. A schematic diagram of LCA stages is displayed in Fig. 4.

#### **Fig. 4**

#### *2.4.1. Goal and scope definition*

In LCA method, the scope includes boundaries of system and detailed level, which depend on the topic and the special usage of the study in consideration [99]. Depending on the target of a

special LCA, the depth and the expanse of LCA can vary significantly. In this research, the border of the system is from the planting step to the SOP stage and it contains the agricultural phase, including preparing soil such as sowing, planting, disease, and weed control, and harvesting steps and industrial phase including oil extraction by cold press. In addition, in both agricultural and industrial phases, the application of PV and PV/T were considered as separate scenarios. It can be identified as a cradle to grave assessment. Fig. 5 shows the border of the system for the 3 defined scenarios, including Present, PV, and PV/T.

#### **Fig. 5**

The purpose of the current LCA is a thorough evaluation of environmental prospects in the total cycle of fuel generation and utilization, with additives to get better engine efficiency and mitigate environmental emissions.

FU has a significant meaning in LCA, denoting a reference unit for inventory information [100]. In multifunctional analysis, various FUs are utilized depending on the scope of LCA. FU is generally described according to the system's generated output [101]. In this research, the ultimate FU is deliberated to be 1 t of extracted sunflower oil by cold press method.

#### *2.4.2. LCI*

LCI is named as quantification of inputs and outputs of a system, i.e., its substance and energy. This stage is allocated to four sub-stages that happen concurrently. In the first stage, all processes involved in the product's life cycle should be recognized. All processes begin with

crude substances and energy extraction from the environment. Data pertinent to every process have to be gleaned in the second stage. This is the hardest stage in LCA and consumption is at its highest level at this time. Data would be gained from scientific investigations, publications by LCA practitioners and government, and industry documents. The third stage is re-explanation of system borders to get finer control of system borders and remove processes beyond the system. Eventually, outputs and inputs of all processes are regulated with regard to FU [31]. In general, there are two major parts in the assessment of LCA, namely, indirect and direct emissions, as described in the subsequent sections.

#### *2.4.2.1. Indirect emissions*

Indirect emissions are consequences of the reporting entity activities but happen at the origin controlled or possessed via other entities. Indeed, these emissions have connections with the production of various substances in various parts of SOP system (farm to oil extraction). The physical amount of every input is needed for these emissions.

#### *2.4.2.2. Direct emissions*

Emissions of sources that are possessed or controlled via the reported entity are called direct emissions. In this research, various direct emissions are available in several parts as follows. Coefficients for emissions relevant to diesel, burned in agricultural machinery, were derived from the substance data of EcoInvent<sup>®</sup>3.6 [102] and are demonstrated in Table 5.

### **Table 5**

Direct emissions of farms are named On-Farm emissions [103] and are obtained via information for the generation of utilized inputs of crude substances, leading to Off-Farm emissions. Table 6 demonstrates emission coefficients relevant to usage of inputs and disposal of residue to compute the inventory data.

**Table 6**

By applying the IPCC guidance, Eq. (8) is used to compute direct N<sub>2</sub>O emissions [104]:

$$N_2O_{Ninputs-N} = (F_{SN} + F_{ON} + F_{CR}) \times EF_1 \quad (8)$$

where  $N_2O_{Ninputs-N}$  (kg N<sub>2</sub>O-N) represents the direct  $N_2O$ -N emissions amount yearly generated from soil;  $F_{SN}$  (kg N) is the synthetic fertilizer N amount exerted to the soil;  $F_{ON}$  (kg N) demonstrates the organic N additions amount exerted to the soil;  $F_{CR}$  (kg N) denotes the N amount in crop remaining parts putting back to the soil, and  $EF_1$  shows the emission factor for N<sub>2</sub>O emissions from N inputs, kg N<sub>2</sub>O-N/kg N input as shown in Table 6.

For calculation of On-Farm emissions in biocides, PestLCI 2.0 model was used. This model was used to calculate the used pesticide fraction in the technosphere crossing the technosphere-environment borders as an emission to the environment. As a 'field box,' the technosphere, following the field boundaries of an arable field of user-determined dimensions reaches 1 m down the soil column and spreads 100 m up to the air column above the soil (i.e., a box 101 m high with a bottom area equal to the field area). It should be noted that PestLCI 2.0 model considers the emission amount of three environmental segments including air, groundwater,

and surface water, while emissions to the soil outside the technosphere are not involved in this model [106]. Accordingly, another method was used to compute biocides emissions to soil that is given in Table 6.

Heavy metal is a common collective phrase that is exerted to the group of metals and metalloids. Being broadly identified, it is generally exerted to wide-spreading pollutants of ecosystems by various emissions to air, water, or soils. These heavy metals may assemble via repetitious fertilizer usages. Chemical fertilizers can be environmental contamination sources and are hazardous to human health, owing to the existence of heavy metals, residuary additives, and even microbial pathogens, exclusively when they are utilized inappropriately [109]. In sunflower production, heavy metals emissions are associated with the application of fertilizers to the soil [110,111]. There are standard coefficients for computing direct emissions of heavy metals, as shown in Table 7 [112].

### **Table 7**

#### *2.4.3. LCIA*

LCIA step is the third step in LCA. The aim of LCIA is to supply extra information to evaluate a product system's LCI consequences in order to finely realize their environmental significance [31].

The goal of LCIA is to help realize the importance of potential environmental impacts for a production system founded on consequences of LCI analysis [113]. LCIA should assess

potential impacts on “areas of protection” containing human health, natural environment, natural resources, and man-made environment [114].

In the past decade, many methods have been extended for environmental impact evaluation, such as EPS2000, Eco-indicator 99, CML, IMPACT 2002+ [115], etc. In this research, IMPACT 2002+ is utilized for assessing environmental loads. It offers a feasible execution of a composed midpoint/damage strategy, connecting all kinds of LCI consequences (primary streams and the other interventions) through 14 midpoint classifications to four damage classifications, comprising human health, ecosystem quality, climate alteration, and resources. Midpoint strategy is deliberated to be less scientifically tested and of lesser dubiety. On the other hand, endpoint index is described in the areas of conservation, whereas midpoint index demonstrates effects among inventory consequence and endpoint.

Endpoint strategy has much more dubiety but can result in rather comprehensible consequences, which renders it easier to reach a decision [116]. The connections among midpoints and endpoints of IMPACT 2002+ method are shown in Fig. 6.

### **Fig. 6**

#### *2.4.4. Life cycle interpretation*

Life cycle commentary is the ultimate step of LCA process, in which consequences of LCI or LCIA, or both, are summed up for results, suggestions, and making decisions consistent with the objectives [31,117].

### *2.5. CED analysis*

As the impact indicator, CED considers the primary energy demanded all over the cradle-to-gate life cycle and indicates the depletion of energy resources regarding the system's life cycle [34,118]. Although the energy use pattern can be possibly used to estimate the energy efficiency of SOP by the ratio of output energy to the sum of inputs energy, the main factor will be missed because the energy resources of inputs are not clear. Accordingly, the CED method of LCA is utilized in this research for determination of energy resources that were applied to production of inputs. This method can help us to find the direct effect of applying solar systems to energy resources management and offer realistic suggestions for next studies. Three main indices of CED analysis surveyed in this study are displayed in Fig. 7.

**Fig. 7**

### *2.6. Sensitivity analysis*

Sensitivity analysis is considered as a study of how dubiety in the output of a mathematical system or model (numeral or in other ways), dividing to various origins of dubiety in its inputs [119]. The sensitivity analysis of four damage classifications on inputs and output factors is accomplished by modifying their contents with  $\pm 10\%$ . Chemical fertilizers, diesel fuel, PV, and PV/T panels are considered as independent variables, while dependent variables are four damage classifications.

Excel 2019 spreadsheet is used to compute parameters and conduct various analyses in this research. Meteonorm software V.7 and TRNSYS V.16 are used for meteorology data extraction and solar systems design. Moreover, PestLCI 2.0 model is performed by using Analytica 5.0. Finally, SimaPro V9.0.0 software is utilized to carry out analysis on LCA and CED.

### **3. Results and Discussions**

#### *3.1. Analysis of input-output energy in SOP*

The inputs and outputs amounts for agricultural and industrial phases of SOP, along with the converted energy quantity of them, were illustrated in Table 8. Experimental results indicated that about 1TSO can be extracted from 9 t of sunflower seed. So, in the agricultural phase, the physical rate of inputs for 9 t of sunflower seed cultivation (about 4 ha) has been stated in the first column of Table 8. Results revealed that the whole energy consumption and generated energy in producing processes of 1TSO were 180354.02 and 39400 MJ, respectively. In addition, results of standard deviation showed that the scattering rate of energy use pattern for sunflower production has a logical amount (between 10 and 40% of average). In other words, there is an appropriate correlation between samples that can be used in applying new energy policies based on the collected data. In the last column of Table 8, the portion of each input for SOP is disclosed. Based on the results, electricity with about 32% (22% in agricultural phase + 10% in industrial phase) had the highest portion in the whole energy consumption followed by nitrogen fertilizer with about 24% and diesel fuel with about 21%. An important result that



can be found from energy analysis of this research is the better performance of industrial phase in comparison with agricultural phase in the production chain of sunflower oil. Actually, only about 14% of total energy use belonged to oil extraction process by cold press method. Of course, the variety of operations with different kinds of used inputs in agricultural production of sunflower is an effective factor for this result.

According to results, electricity is the greatest consumer of energy input in SOP and 70% of it is used in farming phase and 30% is used in oil extraction process. The policy of electrifying water wells by the Ministry of Power of Iran to lift water for irrigation is the most important reason for the increase in electricity consumption in agricultural section [81]. On the other hand, having deep wells in the studied region with low performance and using old mechanisms of irrigation cause more consumption of electricity for extracting water for irrigation. As mentioned above, industrial phase of SOP is also effective in electricity consumption. Cold press method that is only dependent on electricity for extracting oil, is a really old method but unfortunately, is common in the studied area for SOP. Another important cause of the high consumption of electricity in SOP is its low cost. Actually, electricity in Iran has not a real price for consumer. A major part of subsidy paid to producers of sunflower oil is related to the electricity price. Although supporting sunflower farmers is vital, inappropriate allocation of its resources can have destructive effects on agri-food sector. Supplying electricity energy by solar systems is an applicable solution for saving fossil resources. Therefore, in this research, PV

and PV/T systems are considered as alternative resources. Indeed, other objectives are considered for applying solar technologies.

### **Table 8**

Energy analysis indicated that nitrogen is the next energy consumer input. Although increasing the use of nitrogen can increase the sunflower yield, irregular application of it can disturb the energetic balance. In other words, the input energy will be increased with a higher rate in comparison with output energy. Therefore, energy use efficiency will be decreased significantly. Of course, more use of nitrogen causes the reduction of sunflower quality, and finally, extracted oil will be dangerous for people.

Optimal use of chemical fertilizers would be advantageous not only in maintaining sustainability of SOP, but also in reducing negative effects to environment. Lack of knowledge on how to use fertilizer properly and do not use soil analysis in the area leads to unconscious consumption of chemical fertilizer. It is suggested that new policies are to be taken to reduce the negative effects of energy inputs such as plant, soil and climate pollution [120,121].

According to the above-mentioned literature review, there are few studies that have focused on energy balance in both agriculture and industry systems of vegetable oil production, and most researchers surveyed crop production and oil extraction in separate studies. However, de Souza et al. [122] reported that agricultural phase of palm vegetable oil consumed about 8810 MJ energy inputs per ha, and in oil extraction process, this rate was about 36820 MJ. Their results

revealed that electricity, diesel, and chemical fertilizers were the most significant energy consumer inputs of all. In another study, the total energy use for production of 1 TSO in agricultural and industrial phases was estimated at about 90000 MJ, and diesel, electricity, and chemical fertilizers were the main hotspots in energy perspective [40]. Unakitan and Aydın [73], in a one-dimensional study on agricultural phase, computed that diesel fuel and chemical fertilizers had the largest segment of the whole energy use in sunflower production as a resource for biodiesel.

### *3.2. Simulation of PV and PV/T systems*

Based on Table 8, diesel fuel energy use in agricultural phase was about 36973.15 MJ per ha, and the equivalent electricity consumption was estimated at about 3099.17 kWh. In other words, the energy requirement of diesel fuel can be supplied by 3099.17 kWh of renewable electricity. Moreover, the straight electricity power consumed in agricultural phase was about 3304.30 kWh. So, the electricity required to simulate PV and PVT systems was estimated at about 6403.47 kWh for a six months-farming period. Accordingly, about 1067.25 kWh was needed each month. In industrial phase, only the electricity input was needed for the simulation process and this rate was 1500 kWh. Due to sunflower oil extraction in all months of the year, about 125 kWh was examined per t of sunflower oil extraction in each month. After uploading meteorological data to Meteonorm software, the TRNSYS model evaluated various numbers of PV and PV/T panels for supplying determined energy and their results are shown in Table

9. The results revealed that in agricultural phase, the spring season needs more panel in comparison with summer, and the reason is the increase in sun hours in the summer. Moreover, the maximum number of PV and PV/T panels belonged to April with 23 PV and 22 PV/T panels that generated about 1083.57 and 1082.70 kWh energy, respectively.

### **Table 9**

As demonstrated in Table 9, in December, TRNSYS calculated that the maximum number of PV and PV/T panels required for industrial phase was 5 and 4, respectively. The produced electricity power by applied panels in industrial phase was about 144.77 and 144.91 kWh, respectively. It should be noted that the low rate of required electricity in industrial phase was a reason for no difference in computed panels in all other months (4 PV and 3 PV/T). An important point in simulating solar systems in this study was the influence of optimal panel slop that was calculated by Khorasanizadeh et al. [123]. Furthermore, Table 9 offered some statistical indices for simulated solar systems. Results showed that the average number of PV and PV/T panels in agricultural phase was 21 and 19 and in industrial phase was 4 and 3, respectively. In addition, the rate of standard deviation in generated power was very low that showed more coloration between different months in the studied area. However, the maximum number of required panels in both PV and PV/T was considered for evaluation of LCA and CED and their results will be expanded in the next sections of present study.

According to Hosseini-Fashami et al. [87], TRNYS predicted about 150 PV and 147 PV/T panels for supplying required electrical power for greenhouse strawberry production in the coldest month of the year.

### *3.3. LCA of SOP*

In this section, the results of LCA analysis for the 3 defined scenarios are expressed.

#### *3.3.1. Inventory analysis*

The target of LCA for quantifying environmental damages of SOP is to render their environmental profile with the intention of identifying their hot spots. FU is deliberated as 1TSO. Two sections are needed for the production of sunflower oil. The first section is the production of sunflower in the farming system that includes all operations, including preparing farms by tillage, planting, controlling diseases and weeds, and harvesting. In other words, all energy inputs entered as LCI in agricultural phase. The next section is extracting sunflower oil by cold press method. The LCI of industrial phase included energy transportation and oil extraction process with consumed inputs such as electricity and lubricating oil. Moreover, the PV and PV/T panels' application entered as LCI in defined scenarios. Table 10 comprehensively illustrated the LCI of 3 scenarios of SOP. Results show that amounts of CO<sub>2</sub> emission owing to diesel fuel usage in SOP is about 2563 kg 1 TSO<sup>-1</sup>.

### **Table 10**

Several factors have effects on On-Farm emissions, including chemical fertilizers, diesel fuel, biocides, etc. Among all, diesel fuel has the most important role in direct emissions of farms. Irregular diesel fuel consumption in the sunflower farming system has several reasons as follows

1- Lack of a tillage system framework:

Primary tillage is the greatest diesel consumer in the land preparation step. Existence of different tillage systems causes the utilization of disproportional agricultural tractors and related implements. Therefore, farmers make traction energy more than the real required value. This issue, more than irregular use of diesel, could disrupt the soil structure for the next operation.

2- Old systems of agricultural machinery:

The low performance of internal combustion engines in old agricultural machinery causes the high usage of diesel fuel. Moreover, the low price of sunflower products is the main reason for inability of farmers to renew the agricultural machinery. In other words, they have to use unstandardized machinery for different operations.

3- Lack of maintenance systems for agricultural machinery

The maintenance principal is not defined in Iranian agricultural systems. In other words, sunflower farmers do not have a schedule for services of agricultural machinery. They only

change the defective parts after the breakdown of the whole machine, while a defective part reduces the performance of engine and finally, will lead to more use of diesel in the system.

Next factor that has a significant effect on environmental damages in the SOP scenarios is the irregular use of chemical fertilizers, especially nitrogen. Low price of nitrogen and lack of agronomical information of farmers are the main reasons for this result. Moreover, there is no difference between sunflower oil that has been produced by organic sunflower seeds and unhealthy sunflower seeds whose cumulative nitrogen is very dangerous for people's health. It should be noted that the production process of nitrogen fertilizer granulation process in Iran exploits non-renewable and fossil resources, including diesel fuel and natural gas [111], whose effect is very obvious in the background emissions and CED results. Electricity is also an effective input in environmental damages, especially climate change and resources. This can mainly be attributed to electricity production from the extraction of fossil fuels and their combustion in the plants with a share of more than 80% [81]. The major causes for the current consequence are the use of old mechanisms of irrigation in agricultural phase and cold press method of oil extraction in industrial phase.

### *3.3.2. Damage assessment of SOP scenarios*

IMPACT 2002+ method has 15 midpoints for calculation of environmental impacts and the rate of each impact is efficient on the related damage. However, in order to keep more coherence in policy making and analysis, damage categories results are generally considered.

Hence, four damage categories of sunflower production in three defined scenarios are addressed, and a summary of consequences is displayed in Table 11.

**Table 11**

Based on Table 11, the total human health damage of Present, PV, and PV/T scenarios is about 0.08 DALY, and ecosystem quality damage categories are 81632.68, 62871.68, and 63804.09 PDF\*m<sup>2</sup>\*yr for producing 1 t of sunflower oil, respectively. Moreover, the total amounts of climate change are 24537.53, 19412.19, and 21261.85 kg CO<sub>2</sub> eq., for Present, PV, and PV/T scenarios, respectively. In the last damage, the resources are evaluated to be about 20456.72, 186549.25, 108345.81, and 148208.61 MJ 1TSO<sup>-1</sup>, respectively. In similar studies about environmental impacts of SOP in Italy, Spinelli et al. [43] reported that the total climate change of agricultural and industrial phases of SOP was about 67000 kg CO<sub>2</sub> eq. for 1TSO.

Fig. 8 displays the distribution of damages categories in the 3 parts including a) Present, b) PV, and c) PV/T scenarios. Results disclose that the direct emissions related to the agricultural phase of sunflower production are the main hotspots in human health (about 90%), ecosystem quality (about 90%), and climate change (about 50%) in all three scenarios; while in the resources damage category, the situation is variable depending on the nature of each scenario. As can be seen in part (a) of Fig. 8, electricity (about 35%), nitrogen (about 30%), and diesel fuel (about 20%) are the main hotspots in Present scenario, respectively. In part (b) of Fig. 8, by replacing PV panels, rather than electricity and diesel fuel in PV scenario, the share of



nitrogen increases significantly (about 50%) because the shares of electricity and diesel are eliminated from this scenario and nitrogen consumption includes the most part of total resources damage in comparison with other inputs. In addition, PV panels (about 20%) obtained the second hotspot for resources damage in this scenario, while in part (c) of Fig. 8, PV/T scenario shows that the PV/T panels have the highest share in resources damage category (about 40%) followed by nitrogen (about 35%).

### **Fig. 8**

In a one-dimension study about the effect of solar technologies in farming system of strawberry production on greenhouse gases, results revealed that On-Farm emissions and diesel fuel in production without solar technologies and On-Farm emissions and solar panels in production with solar technologies were the most emitted items [87].

#### *3.4. CED analysis of SOP scenarios*

The results of quantity analysis of CED for the 3 defined scenarios are illustrated in Table 12. Results indicate that total CED of SOP is about 177537.61, 99054.12, and 132158.08 MJ 1TSO<sup>-1</sup> for Present, PV, and PV/T scenarios, respectively. Approximately, in all scenarios, more than 95% of CED belongs to non-renewable, fossil with 173499.35, 94251.41, and 125620.06 MJ 1TSO<sup>-1</sup> for Present, PV, and PV/T scenarios, respectively. In addition, surveying renewable energies of CED indicates that the amount of renewable, wind, solar, geothermal for Present, PV, and PV/T scenarios is about 555.44, 546.97, and 999.43 MJ 1TSO<sup>-1</sup>, respectively,

while in renewable, water, the energy consumption is about 3482.82, 4255.74, and 5538.59 MJ 1T<sub>SO</sub><sup>-1</sup> for Present, PV, and PV/T scenarios, respectively.

### **Table 12**

In a study on CED of open-field tomato production in Southern and Central European, Ntinis et al. [35] reported that total CED of tomato was about 160500 MJ per t.

Fig. 9 demonstrates the contribution of each input to the component of energy forms in CED. This figure includes 3 parts, including a) Present, b) PV, and c) PV/T scenarios. With respect to part (a) in Fig. 9, electricity in non-renewable, fossil, and renewable, water and nitrogen in renewable, wind, solar, geothermal forms are the main hotspots of CED. Moreover, part (b) of Fig. 9 revealed that the highest share of non-renewable, fossil and renewable, wind, solar, geothermal belongs to nitrogen, while the PV panels had the highest share of renewable, water from CED point of view. The situation of CED distribution in PV/T scenario is different. Based on part (c) of Fig. 9, PV/T panels are the main hotspots in all 3 energy forms of CED.

### **Fig. 9**

With moving to solar systems, although the total emissions of environmental damages reduce in comparison with Present scenario, PV and PV/T panels allocate shares rather than diesel fuel and electricity. Background emissions of panels are effective in climate change and resources. Using non-renewable resources [112] in the panel's production process is significant in

increasing the mentioned categories. Moreover, the CED of PV and PV/T scenarios is sensitive to applying fossil resources in the production process of solar panels.

### *3.5. Determination of the best scenario*

After surveying about defined scenarios, selection of the best scenarios is the outstanding part. For this purpose, two comparisons are needed including LCA and CED that are explained as follows.

#### *3.5.1. Environmental damages comparison*

Fig. 10 shows the environmental damages of the three scenarios with two situations. Based on part (a) of Fig. 10, the quantity amount of weighted damage in all categories and total damages in Present scenario is the highest in comparison to other scenarios. After that, PV/T scenarios are the most emitted scenarios in all items. Part (b) of Fig. 10 disclosed the percentage comparison between defined scenarios. Actually, in this section, Present scenario as a common system for SOP is considered as a base scenario, and the reduction in environmental damages is calculated for PV and PV/T scenarios in comparison with it.

### **Fig. 10**

Results illustrate that applying PV scenario reduces ecosystem quality, climate change, human health, and resource categories by about 28%, 3%, 29%, and 42%, respectively. Furthermore, in the last column of part (b), reduction of total weighted damages is estimated at about 19% for PV scenario. As can be seen in part (b) of Fig. 10, potential of human health, ecosystem

quality, climate change, resources, and total weighted damages categories is about 14%, 3%, 19%, 21%, and 10% for PV/T scenario in comparison with Present scenario, respectively. In other words, PV in comparison to PV/T can save about 14%, less than 1%, 10%, 21%, and 10% of human health, ecosystem quality, climate change, resources, and total weighted damages, respectively.

Hosseini-Fashami et al. [87] reported that applying PV systems can reduce the total environmental impacts of greenhouse strawberry production by about 16%. In a similar result with the present study, their results indicated that climate changes and resources were the most influential categories by applying solar systems.

### *3.5.2. CED comparison*

Comparison between total CED for Present, PV, and PV/T scenarios is divided into two parts, including quantity and percentages surveying, that is shown in Fig. 11. Actually, in part (a) of Fig. 11, the results of quantity revealed that total CED of Present, PV, and PV/T scenarios is about 49, 28, and 37 MWh. As can be seen in part (b) of Fig. 11, if the Present scenario is considered as a base scenario, PV and PV/T systems can save about 44% and 26% of total CED. In another perspective, PV has a better performance in comparison with PV/T (about 18%) from CED point of view.

**Fig. 11**

Overall, it can be concluded that applying solar technologies reduce environmental damages and CED, significantly, in comparison with Present scenario. However, PV scenario has a better situation compared with PV/T scenario in both LCA and CED approaches. Accordingly, it can be announced that the PV system is the best scenario for producing electricity in the sunflower oil production process in both agricultural and industrial phases.

### *3.5.3. Sensitivity analysis results*

Sensitivity analysis for various damage categories connected with each scenario of parameters regarding input and output is presented in Fig. 12. The average environmental impact of every damage category is demonstrated in the vertical line in the graph. How a damage category is changed via a ten percent increase or decrease ( $\pm 10\%$ ) in the average value of each input and output parameter can be understood from the deviation of the vertical line. As can be observed from sensitivity analysis results, chemical fertilizers have the most alteration at all damage categories, which stems from their fundamental role in the overall contribution. In part (a) of Fig. 12, diesel fuel in ecosystem quality and climate changes and electricity in resources are in the second place, which signifies the important role of non-renewable energies in SOP. With respect to parts (b) and (c) of Fig. 12, it can be concluded that the PV and PV/T panels background processes are significantly effective in climate change and resource damage emissions.

**Fig. 12**

As mentioned before, LCA-CED comparison of all defined scenarios indicates the better performance of PV scenario towards PV/T systems. Note that high ambient temperature of warm seasons in West Azerbaijan province in Iran causes the low difference between PV and PV/T efficiencies, while PV/T systems have extra implements for cooling panels. On the other hand, these mentioned implements cause more energy consumption and damage emissions in the background production process of PV/T panels. Of course, PV/T scenario in comparison with Present scenario has a better situation. This subject indicates that even applying solar systems with non-requirement cooling implement is more justifiable in comparison with application of fossil resources such as diesel fuel and electricity that are generated by non-renewable energies. Finally, a comprehensive investigation of energy-LCA-CED between scenarios indicates that PV scenario is the best among all.

### *3.6. Managerial implications*

The obtained results that were comprehensively expressed above can be useful but are not enough. Offering early and late return strategies is very important for improvement of SOP in the future. Accordingly, the following early and late return strategies are proposed with respect to the results:

#### A. Early return strategies:

- Applying reduced tillage and no-tillage systems for reducing diesel fuel consumption
- Using bio-fertilizers instead of chemical fertilizers especially nitrogen

- Reducing biocides by using modern methods of spraying or utilizing organic methods such as the biological struggle to counter weeds or pests
- Using electropumps with high efficiency instead of old pumps that use electricity or diesel fuel
- Offering a schedule for maintenance of agricultural machinery and cold press machines of extracting oil
- Providing economical facilities such as low interest loans (4%) without breathing for changing old agricultural machinery
- Tax exemption for sunflower oil producers that apply PV systems in both agricultural and industrial phases
- Offering a 15% discount on tax to farmers who apply the standard rate of inputs in PV scenario
- Establishment of vegetable oil producers syndicate in Iran

B. Late return strategies:

- Providing standard patterns of inputs consumption by concentrating on electricity and diesel (in Present scenario) and nitrogen fertilizers (in PV scenario).
- Penalty policies for irregular consumption of chemical fertilizers, especially nitrogen, for farmers who use solar technologies
- Preventing the establishment of PV/T systems and encouragement to apply PV systems

- Providing economical facilities such as low interest loans (4%) with 5 years of breathing for establishment of PV systems
- Pricing of diesel fuel and electricity based on real rate
- Making policy to apply separate prices for organic and non-organic vegetable oil
- Limitation of chemical contents of the oilseed for extracting oil
- Designing, building, and using standard engines in agricultural equipment to accommodate biofuels in this industry

#### **4. Conclusions**

The aim of the present study is to evaluate possibility of solar technologies application in sunflower oil production in Iran. For this purpose exergoenvironmental efficiency of different systems are investigated. The following important results are obtained from this research:

1. Total energy use of agricultural and industrial phases is about 180354 MJ per t of SOP, from which 14% belongs to oil extraction phase and the remaining 86% belongs to agricultural phase. Moreover, 39400 MJ can be obtained by 1TSO.
2. The largest consumer of energy input is electricity with about 32% of total energy use followed by nitrogen (24%) and diesel (21%).
3. Direct emissions had the highest share of human health (90%), ecosystem quality (90%), and climate change (50%) in all scenarios.
4. Total CED of SOP is about 177537.61, 99054.12, and 132158.08 MJ 1TSO<sup>-1</sup> for Present, PV, and PV/T scenarios, respectively.



5. Sensitivity analysis results reveal that chemical fertilizers are the most sensitive inputs in all damages of three defined scenarios. Of course, in climate changes and resources, electricity, PV, and PV/T panels have the highest rate of sensitivity in Present, PV, and PV/T scenarios, respectively.
6. In all environmental damages and energy forms of CED, PV scenario has the lowest rate, and PV/T scenario is in the next place. Summarizing the results show that PV system is the most environmentally friendly scenario among all.
7. Finally, it is recommended that more studies such as life cycle cost analysis and multi-objective optimization of energy-environmental impact assessment of SOP to be done for enhancement of energy efficiency and improve environmental condition.

Application of sustainable methods of agricultural systems in sunflower production such as utilization of electropumps with more efficiency, biofertilizers, standard machinery with timely maintenance and determination of appropriate early and late return strategies mentioned in this study can lead to acceptable production of sunflower oil as an alternative energy resource. Also the results of this research can be used as an approach for policy makers in the case of using clean solar energy in various applications.

### **Acknowledgements**

We gratefully acknowledge the financial support provided by the Management of Fruit and Vegetables Organizations, Tehran Municipality of Iran. Moreover, the first author would like

to express his gratitude to Ms. Tayebah Fallahi-Pashaki for her helpful in the primary steps of this research.

## References

- [1] Faleh N, Khila Z, Wahada Z, Pons M-N, Houas A, Hajjaji N. Exergo-environmental life cycle assessment of biodiesel production from mutton tallow transesterification. *Renew Energy* 2018;127:74–83.
- [2] Fontaras G, Skoulou V, Zanakis G, Zabaniotou A, Samaras Z. Integrated environmental assessment of energy crops for biofuel and energy production in Greece. *Renew Energy* 2012;43:201–9.
- [3] Koçar G, Civaş N. An overview of biofuels from energy crops: Current status and future prospects. *Renew Sustain Energy Rev* 2013;28:900–16.
- [4] Millinger M, Meisel K, Thrän D. Greenhouse gas abatement optimal deployment of biofuels from crops in Germany. *Transp Res Part D Transp Environ* 2019;69:265–75.
- [5] Thirumarimurugan M, Sivakumar VM, Xavier AM, Prabhakaran D, Kannadasan T. Preparation of biodiesel from sunflower oil by transesterification. *Int J Biosci Bioinforma* 2012;2:441–4.
- [6] Yang SM. A Culture of *Puccinia helianthi* Pathogenic to All Known Resistant Sunflower Genotypes. *Plant Dis* 1987;71:101.
- [7] Harborne J. The new oxford book of food plants. *Phytochemistry* 1998;47:1666.
- [8] Lebeda A, Pavelková J, Urban J, Sedláková B. Distribution, host range and disease severity of *Pseudoperonospora cubensis* on cucurbits in the Czech Republic. *J Phytopathol* 2011;159:589–96.
- [9] Gbogouri G, Brou K, Beugre G, Gnakri D, Linder M. Assessment of the thermo-oxidation of three cucurbit seed oils by differential scanning calorimetry. *Innov Rom Food Biotechnol* 2013;12:32–9.
- [10] Saydut A, Erdogan S, Kafadar A, Kaya C, Aydin F, Hamamci C. Process optimization for production of biodiesel from hazelnut oil, sunflower oil and their hybrid feedstock. *Fuel* 2016;183:512–7.
- [11] Jahirul M, Rasul M, Chowdhury A, Ashwath N. Biofuels production through biomass pyrolysis —A technological review. *Energies* 2012;5:4952–5001.

- [12] Bäumler ER, Carrín ME, Carelli AA. Extraction of sunflower oil using ethanol as solvent. *J Food Eng* 2016;178:190–7.
- [13] Chew SC. Cold-pressed rapeseed (*Brassica napus*) oil: Chemistry and functionality. *Food Res Int* 2020;131:108997.
- [14] Chen X, Shuai C, Zhang Y, Wu Y. Decomposition of energy consumption and its decoupling with economic growth in the global agricultural industry. *Environ Impact Assess Rev* 2020;81.
- [15] Mostashari-Rad F, Nabavi-Pelesaraei A, Soheilifard F, Hosseini-Fashami F, Chau KW. Energy optimization and greenhouse gas emissions mitigation for agricultural and horticultural systems in Northern Iran. *Energy* 2019;186:115845.
- [16] Alhajj Ali S, Tedone L, De Mastro G. A comparison of the energy consumption of rainfed durum wheat under different management scenarios in southern Italy. *Energy* 2013;61:308–18.
- [17] Alluvione F, Moretti B, Sacco D, Grignani C. EUE (energy use efficiency) of cropping systems for a sustainable agriculture. *Energy* 2011;36:4468–81.
- [18] Adenle AA. Assessment of solar energy technologies in Africa-opportunities and challenges in meeting the 2030 agenda and sustainable development goals. *Energy Policy* 2020;137:111180.
- [19] Khorasanizadeh H, Mohammadi K. Introducing the best model for predicting the monthly mean global solar radiation over six major cities of Iran. *Energy* 2013;51:257–66.
- [20] Heng Y, Lu CL, Yu L, Gao Z. The heterogeneous preferences for solar energy policies among US households. *Energy Policy* 2020;137:111187.
- [21] SEIA. Solar Industry Data. <https://www.seia.org/solar-industry-data>. 2018.
- [22] Watson S, Bian D, Sahraei N, Winter AG, Buonassisi T, Peters IM. Advantages of operation flexibility and load sizing for PV-powered system design. *Sol Energy* 2018;162:132–9.
- [23] Al-Waeli AHA, Sopian K, Kazem HA, Chaichan MT. Photovoltaic/Thermal (PV/T) systems: Status and future prospects. *Renew Sustain Energy Rev* 2017;77:109–30.
- [24] Šúri M, Huld TA, Dunlop ED, Ossenbrink HA. Potential of solar electricity generation in the European Union member states and candidate countries. *Sol Energy* 2007;81:1295–305.

- [25] Agrawal B, Tiwari GN. Optimizing the energy and exergy of building integrated photovoltaic thermal (BIPVT) systems under cold climatic conditions. *Appl Energy* 2010;87:417–26.
- [26] Dubey S, Tiwari GN. Thermal modeling of a combined system of photovoltaic thermal (PV/T) solar water heater. *Sol Energy* 2008;82:602–12.
- [27] Rosell JI, Vallverdú X, Lechón MA, Ibáñez M. Design and simulation of a low concentrating photovoltaic/thermal system. *Energy Convers Manag* 2005;46:3034–46.
- [28] Abu Bakar MN, Othman M, Hj Din M, Manaf NA, Jarimi H. Design concept and mathematical model of a bi-fluid photovoltaic/thermal (PV/T) solar collector. *Renew Energy* 2014;67:153–64.
- [29] Qiu GY, Zhang X, Yu X, Zou Z. The increasing effects in energy and GHG emission caused by groundwater level declines in North China's main food production plain. *Agric Water Manag* 2018;203:138–50.
- [30] Galford GL, Peña O, Sullivan AK, Nash J, Gurwick N, Pirolli G, et al. Agricultural development addresses food loss and waste while reducing greenhouse gas emissions. *Sci Total Environ* 2020;699:134318.
- [31] ISO. 14040 International standard. *Environmental Management–Life Cycle Assessment–Principles and Framework*, International Organisation for Standardization, Geneva, Switzerland. 2006.
- [32] Cordella M, Hidalgo C. Analysis of key environmental areas in the design and labelling of furniture products: Application of a screening approach based on a literature review of LCA studies. *Sustain Prod Consum* 2016;8:64–77.
- [33] Roostaei J, Zhang Y. Spatially Explicit Life Cycle Assessment: Opportunities and challenges of wastewater-based algal biofuels in the United States. *Algal Res* 2017;24:395–402.
- [34] Frischknecht R, Wyss F, Büsler Knöpfel S, Lützkendorf T, Balouktsi M. Cumulative energy demand in LCA: the energy harvested approach. *Int J Life Cycle Assess* 2015;20:957–69.
- [35] Ntinis GK, Neumair M, Tsadilas CD, Meyer J. Carbon footprint and cumulative energy demand of greenhouse and open-field tomato cultivation systems under Southern and Central European climatic conditions. *J Clean Prod* 2017;142:3617–26.
- [36] Wagner HJ, Pick E. Energy yield ratio and cumulative energy demand for wind energy converters. *Energy* 2004;29:2289–95.

- [37] Pelletier N, Arsenault N, Tyedmers P. Scenario modeling potential eco-efficiency gains from a transition to organic agriculture: life cycle perspectives on Canadian canola, corn, soy, and wheat production. *Environ Manage* 2008;42:989–1001.
- [38] Dalgaard R, Schmidt J, Halberg N, Christensen P, Thrane M, Pengue WA. LCA of soybean meal. *Int J Life Cycle Assess* 2008;13:240–54.
- [39] Sanz Requena JF, Guimaraes AC, Quirós Alpera S, Relea Gangas E, Hernandez-Navarro S, Navas Gracia LM, et al. Life Cycle Assessment (LCA) of the biofuel production process from sunflower oil, rapeseed oil and soybean oil. *Fuel Process Technol* 2011;92:190–9.
- [40] Özilgen M, Sorgüven E. Energy and exergy utilization, and carbon dioxide emission in vegetable oil production. *Energy* 2011;36:5954–67.
- [41] Knudsen MT, Fonseca de Almeida G, Langer V, Santiago de Abreu L, Halberg N. Environmental assessment of organic juice imported to Denmark: a case study on oranges (*Citrus sinensis*) from Brazil. *Org Agric* 2011;1:167–85.
- [42] Boulard T, Raeppele C, Brun R, Lecompte F, Hayer F, Carmassi G, et al. Environmental impact of greenhouse tomato production in France. *Agron Sustain Dev* 2011;31:757–77.
- [43] Spinelli D, Jez S, Basosi R. Integrated Environmental Assessment of sunflower oil production. *Process Biochem* 2012;47:1595–602.
- [44] Figueiredo F, Castanheira É, Freire F. LCA of sunflower oil addressing alternative land use change scenarios and practices. 8th Int. Conf. LCA Agri-Food Sect., vol. 14044, 2012, p. 2–4.
- [45] Spinelli D, Jez S, Pogni R, Basosi R. Environmental and life cycle analysis of a biodiesel production line from sunflower in the Province of Siena (Italy). *Energy Policy* 2013;59:492–506.
- [46] Herrmann IT, Jørgensen A, Bruun S, Hauschild MZ. Potential for optimized production and use of rapeseed biodiesel. Based on a comprehensive real-time LCA case study in Denmark with multiple pathways. *Int J Life Cycle Assess* 2013;18:418–30.
- [47] Nucci B, Puccini M, Pelagagge L, Vitolo S, Nicoletta C. Improving the environmental performance of vegetable oil processing through LCA. *J Clean Prod* 2014;64:310–22.
- [48] Palmieri N, Forleo MB, Suardi A, Coaloa D, Pari L. Rapeseed for energy production: Environmental impacts and cultivation methods. *Biomass and Bioenergy* 2014;69:1–11.
- [49] Kouchaki-Penchah H, Sharifi M, Mousazadeh H, Zarea-Hosseiniabadi H, Nabavi-

- Pelesaraei A. Gate to gate life cycle assessment of flat pressed particleboard production in Islamic Republic of Iran. *J Clean Prod* 2016;112:343–50.
- [50] Harris TM, Hottle TA, Soratana K, Klane J, Landis AE. Life cycle assessment of sunflower cultivation on abandoned mine land for biodiesel production. *J Clean Prod* 2016;112:182–95.
- [51] Hassanien RHE, Li M, Dong Lin W. Advanced applications of solar energy in agricultural greenhouses. *Renew Sustain Energy Rev* 2016;54:989–1001.
- [52] Christoforou EA, Fokaides PA. Life cycle assessment (LCA) of olive husk torrefaction. *Renew Energy* 2016;90:257–66.
- [53] Boone L, Van linden V, De Meester S, Vandecasteele B, Muylle H, Roldán-Ruiz I, et al. Environmental life cycle assessment of grain maize production: An analysis of factors causing variability. *Sci Total Environ* 2016;553:551–64.
- [54] Taki M, Ajabshirchi Y, Ranjbar SF, Rohani A, Matloobi M. Heat transfer and MLP neural network models to predict inside environment variables and energy lost in a semi-solar greenhouse. *Energy Build* 2016;110:314–29.
- [55] Mousavi-Avval SH, Rafiee S, Sharifi M, Hosseinpour S, Notarnicola B, Tassielli G, et al. Application of multi-objective genetic algorithms for optimization of energy, economics and environmental life cycle assessment in oilseed production. *J Clean Prod* 2017;140:804–15.
- [56] Mousavi-Avval SH, Rafiee S, Sharifi M, Hosseinpour S, Notarnicola B, Tassielli G, et al. Use of LCA indicators to assess Iranian rapeseed production systems with different residue management practices. *Ecol Indic* 2017;80:31–9.
- [57] Yu Y, Liu J, Wang Y, Xiang C, Zhou J. Practicality of using solar energy for cassava irrigation in the Guangxi Autonomous Region, China. *Appl Energy* 2018;230:31–41.
- [58] Nabavi-Pelesaraei A, Rafiee S, Mohtasebi SS, Hosseinzadeh-Bandbafha H, Chau KW. Assessment of optimized pattern in milling factories of rice production based on energy, environmental and economic objectives. *Energy* 2019;169:1259–73.
- [59] Farahani SS, Soheilifard F, Ghasemi Nejad Raini M, Kokei D. Comparison of different tomato puree production phases from an environmental point of view. *Int J Life Cycle Assess* 2019;24:1817–27.
- [60] Nabavi-Pelesaraei A, Rafiee S, Mohtasebi SS, Hosseinzadeh-Bandbafha H, Chau KW. Comprehensive model of energy, environmental impacts and economic in rice milling factories by coupling adaptive neuro-fuzzy inference system and life cycle assessment.

- J Clean Prod 2019;217:742–56.
- [61] Hosseini-Fashami F, Motevali A, Nabavi-Pelesaraei A, Hashemi SJ, Chau KW. Energy-Life cycle assessment on applying solar technologies for greenhouse strawberry production. *Renew Sustain Energy Rev* 2019;116:109411.
- [62] Saber Z, Esmaili M, Pirdashti H, Motevali A, Nabavi-Pelesaraei A. Exergoenvironmental-Life cycle cost analysis for conventional, low external input and organic systems of rice paddy production. *J Clean Prod* 2020;263:121529.
- [63] Ghasemi-Mobtaker H, Mostashari-Rad F, Saber Z, Chau KW, Nabavi-Pelesaraei A. Application of photovoltaic system to modify energy use, environmental damages and cumulative exergy demand of two irrigation systems-A case study: Barley production of Iran. *Renew Energy* 2020;160:1316–34.
- [64] Khanali M, Akram A, Behzadi J, Mostashari-Rad F, Saber Z, Chau KW., et al. Multi-objective optimization of energy use and environmental emissions for walnut production using imperialist competitive algorithm. *Appl Energy* 2021;284:116342.
- [65] Ministry of Jihad-e-Agriculture of Iran. Annual Agricultural Statistics. [www.maj.ir](http://www.maj.ir) (in Persian). 2019.
- [66] Nabavi-Pelesaraei A, Abdi R, Rafiee S. Energy use pattern and sensitivity analysis of energy inputs and economical models for peanut production in Iran. *Int J Agric Crop Sci* 2013;5:2193–202.
- [67] Hosseinzadeh-Bandbafha H, Safarzadeh D, Ahmadi E, Nabavi-Pelesaraei A, Nabavi-Pelesaraei A. Optimization of energy consumption of dairy farms using data envelopment analysis – A case study: Qazvin city of Iran. *J Saudi Soc Agric Sci* 2018;17:217–28.
- [68] Bakhtiari AA, Hematian A, Sharifi A. Energy analyses and greenhouse gas emissions assessment for saffron production cycle. *Environ Sci Pollut Res* 2015;22:16184–201.
- [69] Kaab A, Sharifi M, Mobli H, Nabavi-Pelesaraei A, Chau KW. Combined life cycle assessment and artificial intelligence for prediction of output energy and environmental impacts of sugarcane production. *Sci Total Environ* 2019;664:1005–19.
- [70] Moitzi G, Neugschwandtner RW, Kaul HP, Wagentristl H. Energy efficiency of winter wheat in a long-term tillage experiment under Pannonian climate conditions. *Eur J Agron* 2019;103:24–31.
- [71] Mousavi-Avval SH, Rafiee S, Jafari A, Mohammadi A. Optimization of energy consumption for soybean production using Data Envelopment Analysis (DEA) approach.

- Appl Energy 2011;88:3765–72.
- [72] Ghasemi-Mobtaker H, Kaab A, Rafiee S. Application of life cycle analysis to assess environmental sustainability of wheat cultivation in the west of Iran. *Energy* 2020;193:116768.
- [73] Unakitan G, Aydın B. A comparison of energy use efficiency and economic analysis of wheat and sunflower production in Turkey: A case study in Thrace Region. *Energy* 2018;149:279–85.
- [74] Pishgar-Komleh SH, Sefeedpari P, Rafiee S. Energy and economic analysis of rice production under different farm levels in Guilan province of Iran. *Energy* 2011;36:5824–31.
- [75] Nabavi-Pelesaraei A, Rafiee S, Mohtasebi SS, Hosseinzadeh-Bandbafha H, Chau KW. Energy consumption enhancement and environmental life cycle assessment in paddy production using optimization techniques. *J Clean Prod* 2017;162:571–86.
- [76] Ozkan B, Kurklu A, Akcaoz H. An input-output energy analysis in greenhouse vegetable production: a case study for Antalya region of Turkey. *Biomass and Bioenergy* 2004;26:89–95.
- [77] Kaab A, Sharifi M, Mobli H, Nabavi-Pelesaraei A, Chau KW. Use of optimization techniques for energy use efficiency and environmental life cycle assessment modification in sugarcane production. *Energy* 2019;181:1298–320.
- [78] Kallivroussis L, Natsis A, Papadakis G. The energy balance of sunflower production for biodiesel in Greece. *Biosyst Eng* 2002;81:347–54.
- [79] Jalali-Sefat M. Energy Economics Study of Jam Production in Razavi Khorasan Province. Faculty of Agriculture. University of Tabriz. M.Sc Thesis. 2013.
- [80] Price L, Sinton J, Worrell E, Phylipsen D, Xiulian H, Ji L. Energy use and carbon dioxide emissions from steel production in China. *Energy* 2002;27:429–46.
- [81] García-Valladares O, Ortiz NM, Pilatowsky I, Menchaca AC. Solar thermal drying plant for agricultural products. Part 1: Direct air heating system. *Renew Energy* 2020;148:1302–20.
- [82] Chow TT. A review on photovoltaic/thermal hybrid solar technology. *Appl Energy* 2010;87:365–79.
- [83] Calise F, Dentice d'Accadia M, Palombo A, Vanoli L. Dynamic simulation of a novel high-temperature solar trigeneration system based on concentrating



- photovoltaic/thermal collectors. *Energy* 2013;61:72–86.
- [84] Jia Y, Alva G, Fang G. Development and applications of photovoltaic–thermal systems: A review. *Renew Sustain Energy Rev* 2019;102:249–65.
- [85] Power Ministry of Iran. Iran’s power industry statistics for strategic management. <http://www.moe.gov.ir/>. 2019.
- [86] Kalogirou SA. Use of TRNSYS for modelling and simulation of a hybrid pv–thermal solar system for Cyprus. *Renew Energy* 2001;23:247–60.
- [87] Hosseini-Fashami F, Motevali A, Nabavi-Pelesaraei A, Hashemi SJ, Chau KW. Energy-Life cycle assessment on applying solar technologies for greenhouse strawberry production. *Renew Sustain Energy Rev* 2019;116:109411.
- [88] Petrakis M, Kambezidis H, Lykoudis S, Adamopoulos A., Kassomenos P, Michaelides I., et al. Generation of a “typical meteorological year” for Nicosia, Cyprus. *Renew Energy* 1998;13:381–8.
- [89] Klein S., Beckman W., Duffie J. A design procedure for solar heating systems. *Sol Energy* 1976;18:113–27.
- [90] Mostashari-Rad F, Ghasemi-Mobtaker H, Taki M, Ghahderijani M, Kaab A, Chau KW, et al. Exergoenvironmental damages assessment of horticultural crops using ReCiPe2016 and cumulative exergy demand frameworks. *J Clean Prod* 2021;278:123788.
- [91] Mostashari-Rad F, Ghasemi-Mobtaker H, Taki M, Ghahderijani M, Saber Z, Chau KW, et al. Data supporting midpoint-weighting life cycle assessment and energy forms of cumulative exergy demand for horticultural crops. *Data Br* 2020;33:106490.
- [92] Yılmaz E, Arslan H, Bideci A. Environmental performance analysis of insulated composite facade panels using life cycle assessment (LCA). *Constr Build Mater* 2019;202:806–13.
- [93] Nabavi-Pelesaraei A, Kaab A, Hosseini-Fashami F, Mostashari-Rad F, Chau KW. Life Cycle Assessment (LCA) Approach to Evaluate Different Waste Management Opportunities. *Adv. Waste-to-Energy Technol.*, CRC Press; 2019, p. 195–216.
- [94] La Rosa A, Banatao D, Pastine S, Latteri A, Cicala G. Recycling treatment of carbon fibre/epoxy composites: Materials recovery and characterization and environmental impacts through life cycle assessment. *Compos Part B Eng* 2016;104:17–25.
- [95] Nabavi-Pelesaraei A, Bayat R, Hosseinzadeh-Bandbafha H, Afrasyabi H, Berrada A.

- Prognostication of energy use and environmental impacts for recycle system of municipal solid waste management. *J Clean Prod* 2017;154:602–13.
- [96] Nabavi-Pelesaraei A, Bayat R, Hosseinzadeh-Bandbafha H, Afrasyabi H, Chau KW. Modeling of energy consumption and environmental life cycle assessment for incineration and landfill systems of municipal solid waste management - A case study in Tehran Metropolis of Iran. *J Clean Prod* 2017;148:427–40.
- [97] Rebitzer G, Ekvall T, Frischknecht R, Hunkeler D, Norris G, Rydberg T, et al. Life cycle assessment: Part 1: Framework, goal and scope definition, inventory analysis, and applications. *Environ Int* 2004;30:701–20.
- [98] Van den Heede P, De Belie N. Environmental impact and life cycle assessment (LCA) of traditional and ‘green’ concretes: Literature review and theoretical calculations.’ *Cem Concr Compos* 2012;34:431–42.
- [99] Houshyar E, Grundmann P. Environmental impacts of energy use in wheat tillage systems: A comparative life cycle assessment (LCA) study in Iran. *Energy* 2017;122:11–24.
- [100] Kylili A, Christoforou E, Fokaides PA. Environmental evaluation of biomass pelleting using life cycle assessment. *Biomass and Bioenergy* 2016;84:107–17.
- [101] Cherubini F, Bargigli S, Ulgiati S. Life cycle assessment (LCA) of waste management strategies: landfilling, sorting plant and incineration. *Energy* 2009;34:2116–23.
- [102] EcoInvent. EcoInvent. (n.d.). System Models in Ecoinvent 3.6. Retrieved 12 September 2019, from <https://www.ecoinvent.org/database/ecoinvent-36/ecoinvent-36.html>. 2019.
- [103] Aljerf L. Data of thematic analysis of farmer's use behavior of recycled industrial wastewater. *Data Br* 2018;21:240–50.
- [104] IPCC. IPCC guidelines for national greenhouse gas inventories. 2 Inst Glob Environ Strateg Hayama, Japan. 2006.
- [105] Nguyen TLT, Hermansen JE. System expansion for handling co-products in LCA of sugar cane bio-energy systems: GHG consequences of using molasses for ethanol production. *Appl Energy* 2012;89:254–61.
- [106] Dijkman TJ, Birkved M, Hauschild MZ. PestLCI 2.0: A second generation model for estimating emissions of pesticides from arable land in LCA. *Int J Life Cycle Assess* 2012;17:973–86.
- [107] Margni M, Rossier D, Crettaz P, Jolliet O. Life cycle impact assessment of pesticides on

- human health and ecosystems. *Agric Ecosyst Environ* 2002;93:379–92.
- [108] Mousavi-Avval SH, Rafiee S, Sharifi M, Hosseinpour S, Shah A. Combined application of Life Cycle Assessment and Adaptive Neuro-Fuzzy Inference System for modeling energy and environmental emissions of oilseed production. *Renew Sustain Energy Rev* 2017;78:807–20.
- [109] Ning CCC, Gao PVP, Wang BQBBQ, Lin WPW, Jiang NNH, Cai KZK. Impacts of chemical fertilizer reduction and organic amendments supplementation on soil nutrient, enzyme activity and heavy metal content. *J Integr Agric* 2017;16:1819–31.
- [110] Lombi E, Gerzabek MH, Horak O. Mobility of heavy metals in soil and their uptake by sunflowers grown at different contamination levels. *Agronomie* 1998;18:361–71.
- [111] Ullah R, Bakht J, Shafi M, Iqbal M, Khan A, Saeed M. Phyto-accumulation of heavy metals by sunflower (*Helianthus annuus* L.) grown on contaminated soil. *African J Biotechnol* 2011;10:17192–8.
- [112] Durlinger B, Koukouna E, Broekema R, van Paassen M, Scholten. *Agri-footprint 3.0*. Blonk Consultants, Gouda, The Netherlands, 2015.
- [113] Liu H, Huang Y, Yuan H, Yin X, Wu C. Life cycle assessment of biofuels in China: Status and challenges. *Renew Sustain Energy Rev* 2018;97:301–22.
- [114] Udo de Haes HA, Finnveden G, Goedkoop M, Hauschild M, Hertwich E, Hofstetter P, et al. *Life cycle impact assessment: striving towards best practice*. Pensacola, Florida: SETAC Press. 2002.
- [115] Klinglmair M, Sala S, Brandão M. Assessing resource depletion in LCA: a review of methods and methodological issues. *Int J Life Cycle Assess* 2014;19:580–92.
- [116] Jolliet O, Margni M, Charles R, Humbert S, Payet J, Rebitzer G, et al. *IMPACT 2002+*: a new life cycle impact assessment methodology. *Int J Life Cycle Assess* 2003;8:324.
- [117] Rashid AFA, Yusoff S. A review of life cycle assessment method for building industry. *Renew Sustain Energy Rev* 2015;45:244–8.
- [118] Bahlawan H, Morini M, Pinelli M, Pogonietz WR, Spina PR, Venturini M. Optimization of a hybrid energy plant by integrating the cumulative energy demand. *Appl Energy* 2019;253:113484.
- [119] Saltelli A, Ratto M, Andres T, Campolongo F, Cariboni J, Gatelli D, et al. *Global Sensitivity Analysis : The Primer*. John Wiley; 2008.
- [120] Mobtaker HG, Akram A, Keyhani A. Energy use and sensitivity analysis of energy

- inputs for alfalfa production in Iran. *Energy Sustain Dev* 2012;16:84–9.
- [121] Nabavi-Pelesaraei A, Amid S. Reduction of greenhouse gas emissions of eggplant production by energy optimization using DEA approach. *Elixir Energy Environ* 2014;69:23696–701.
- [122] de Souza SP, Pacca S, de Ávila MT, Borges JLB. Greenhouse gas emissions and energy balance of palm oil biofuel. *Renew Energy* 2010;35:2552–61.
- [123] Khorasanizadeh H, Aghaei A, Ehteram H. Solar energy potential and determination of optimum angle of solar collectors in Urmia city. *Second Natl. Conf. Wind Sol. Energy, Tehran, Iran: 2012, p. 1–12.*

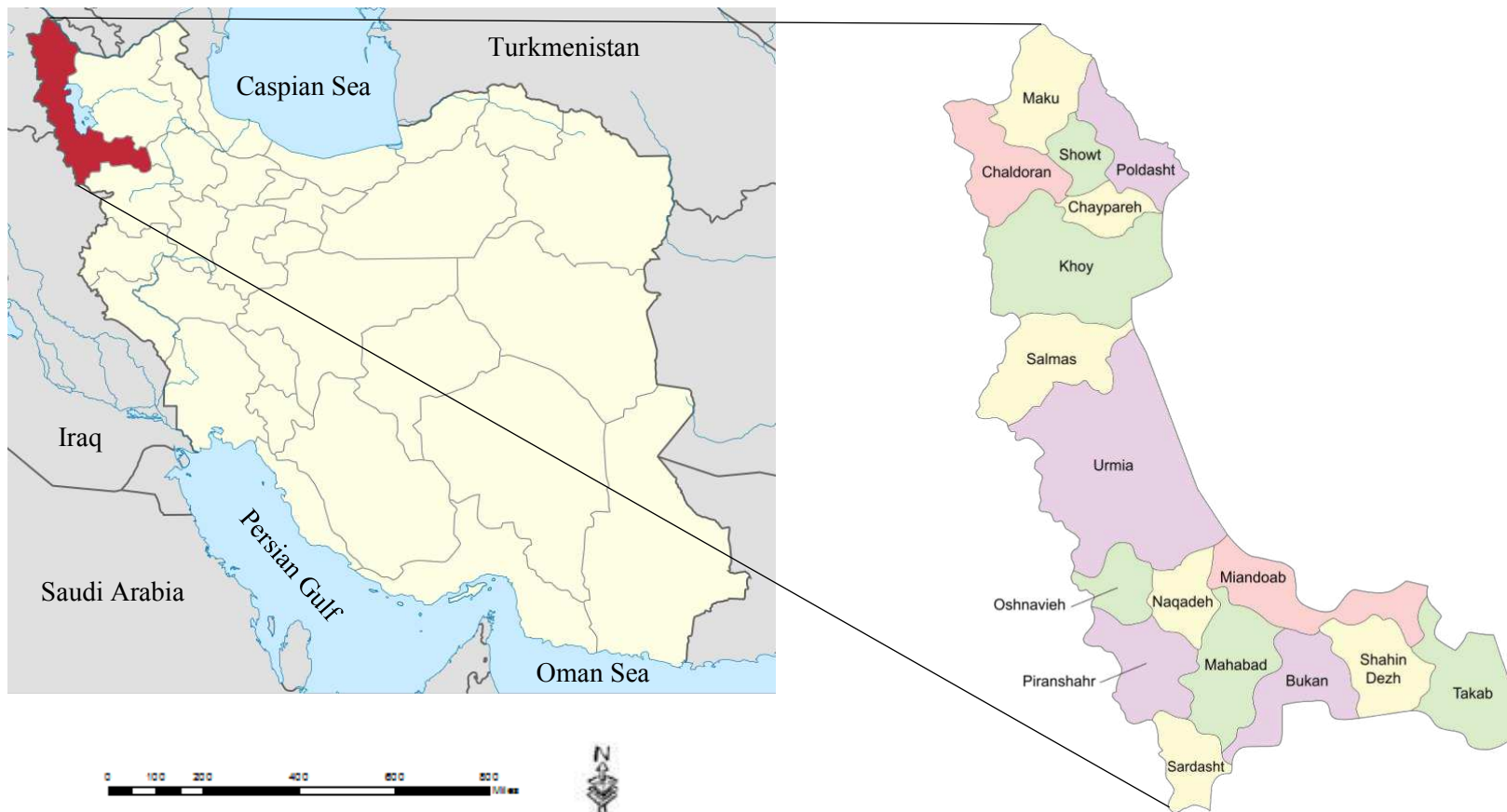

**Fig. 1.** Geographical position of the West Azerbaijan province in the northwest of Iran.

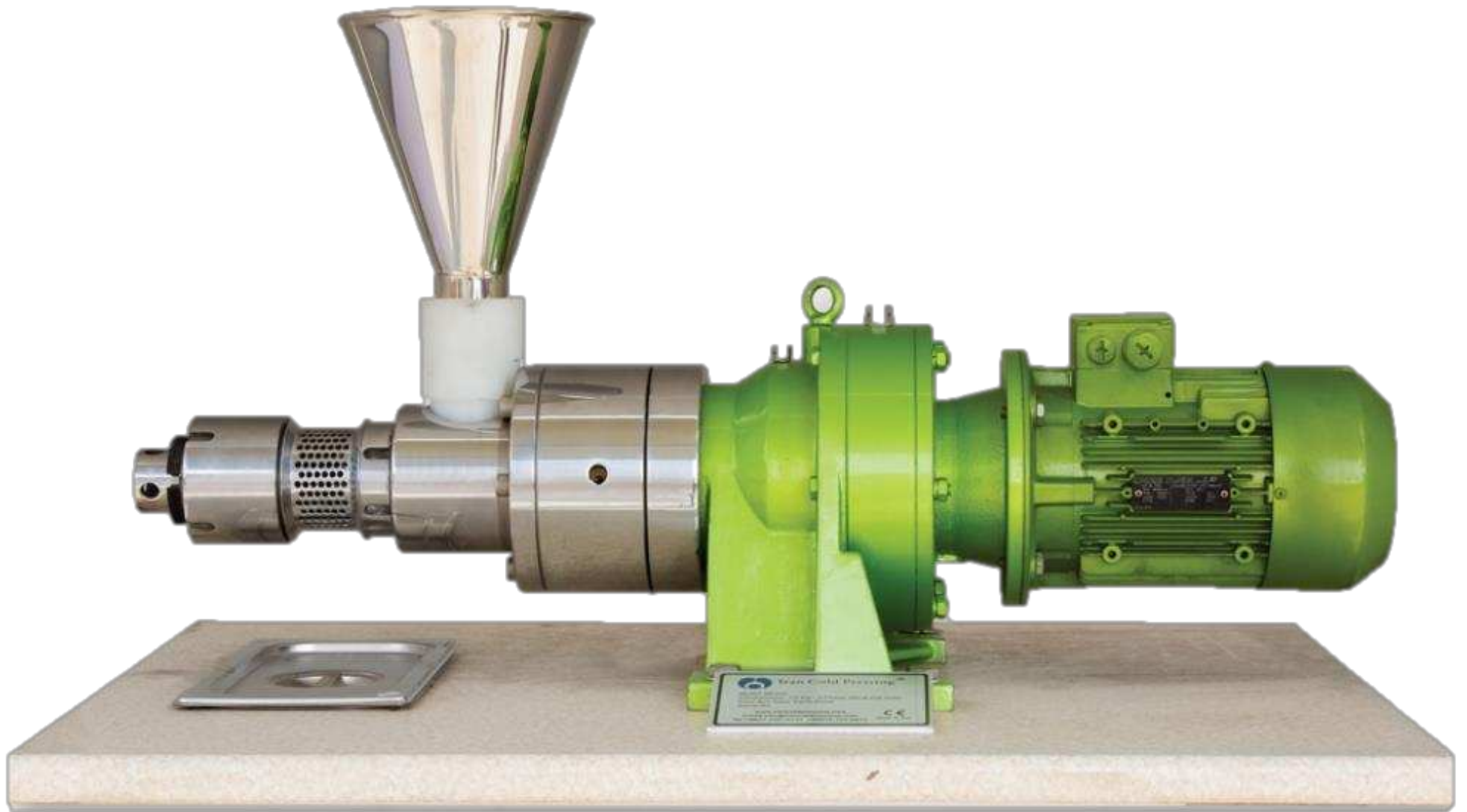

**Fig. 2.** The oil extraction equipment in the present study.

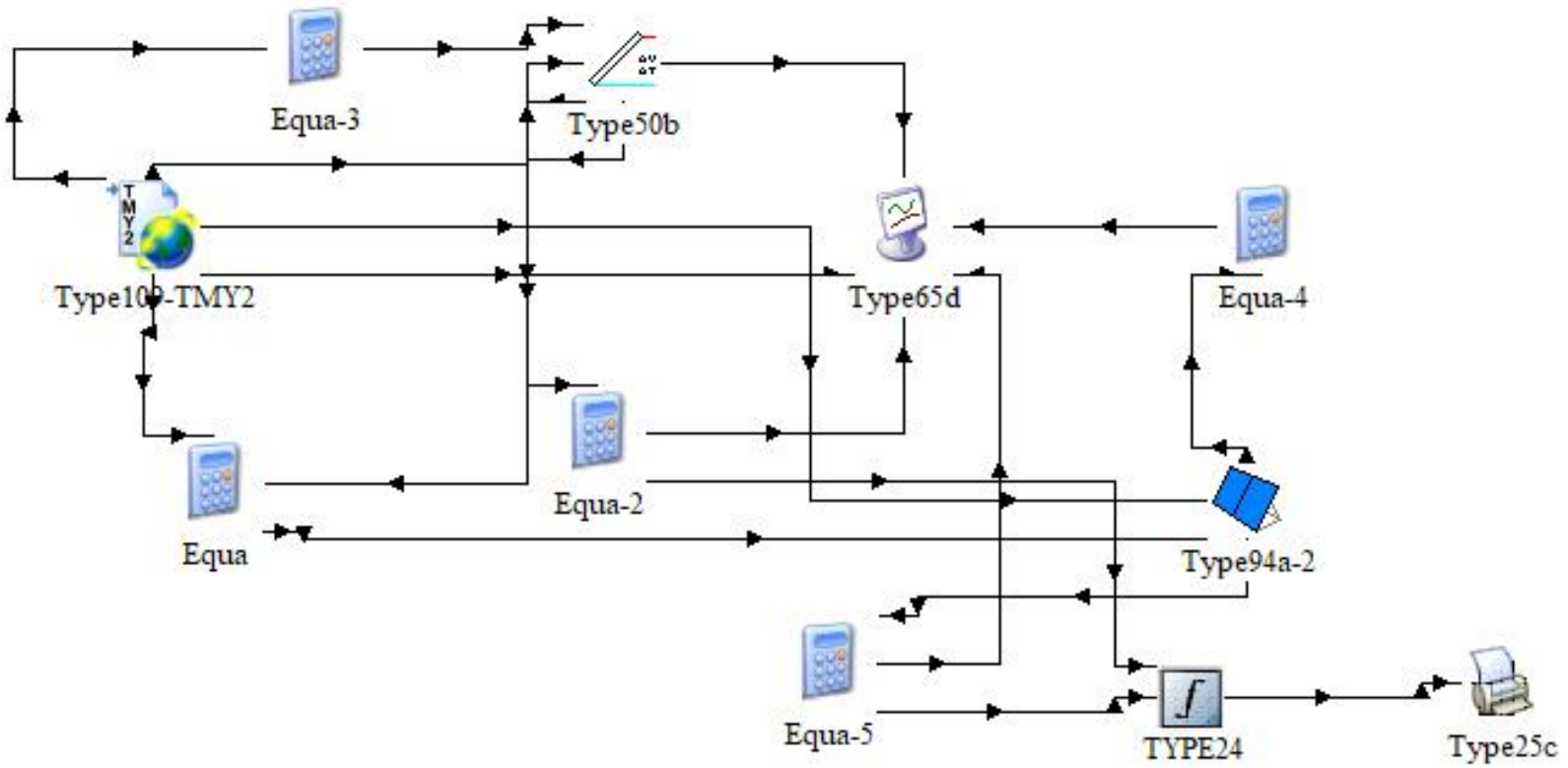

**Fig. 3.** Designed PV and PV/T circulate to establish SOP [59].

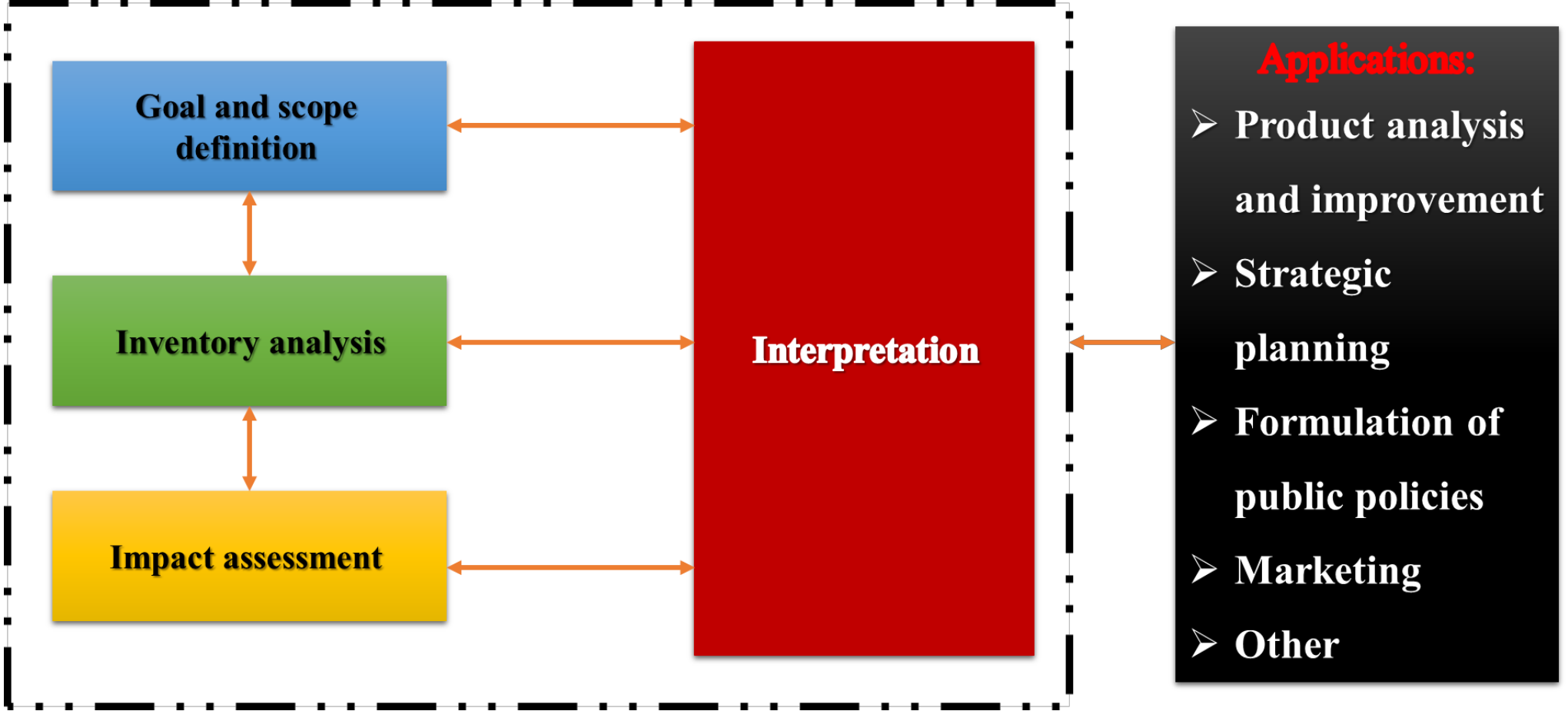

Fig. 4. Schematic diagram of LCA steps.



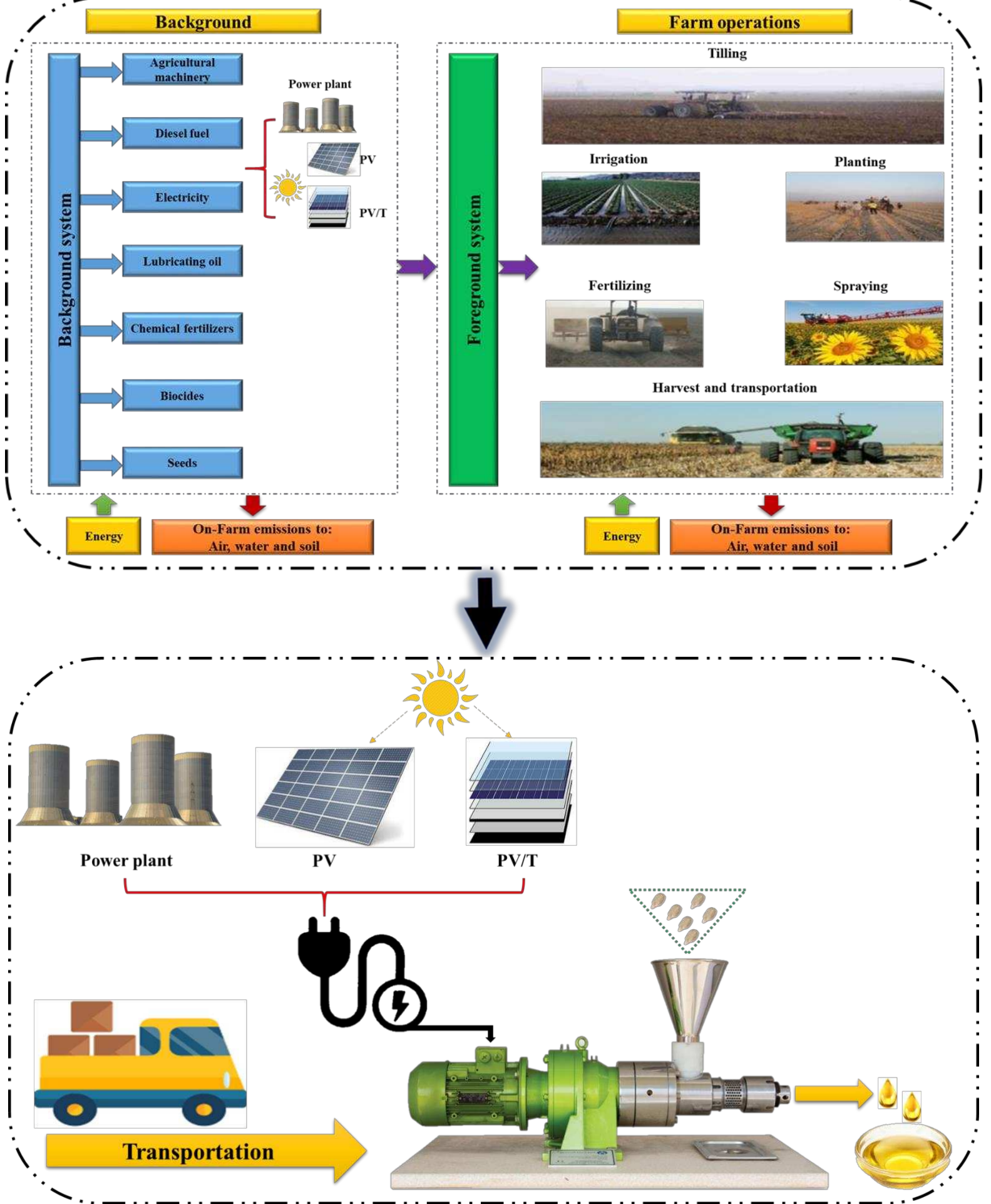

Fig. 5. System boundary including farm to industrial process of SOP.

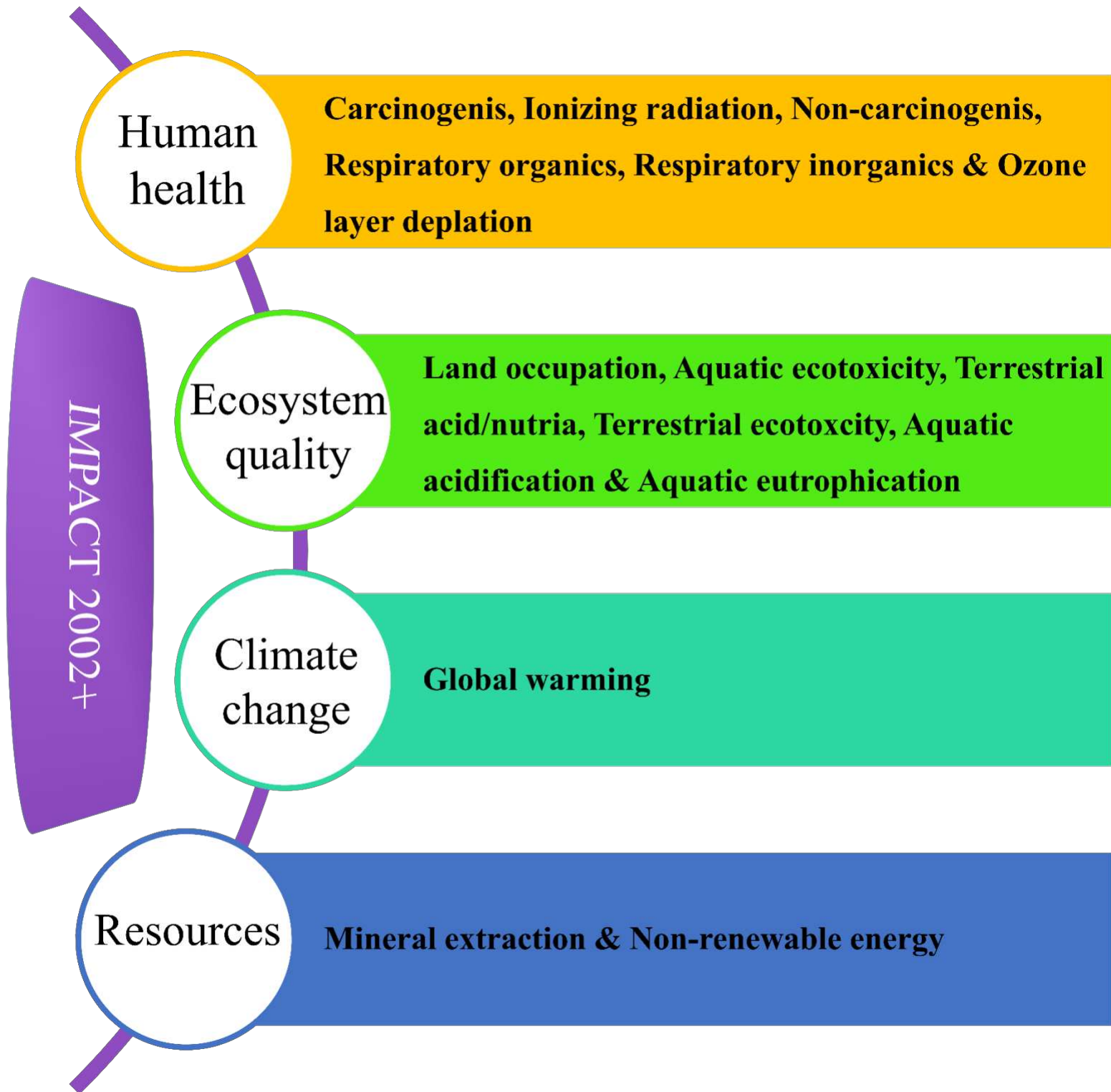
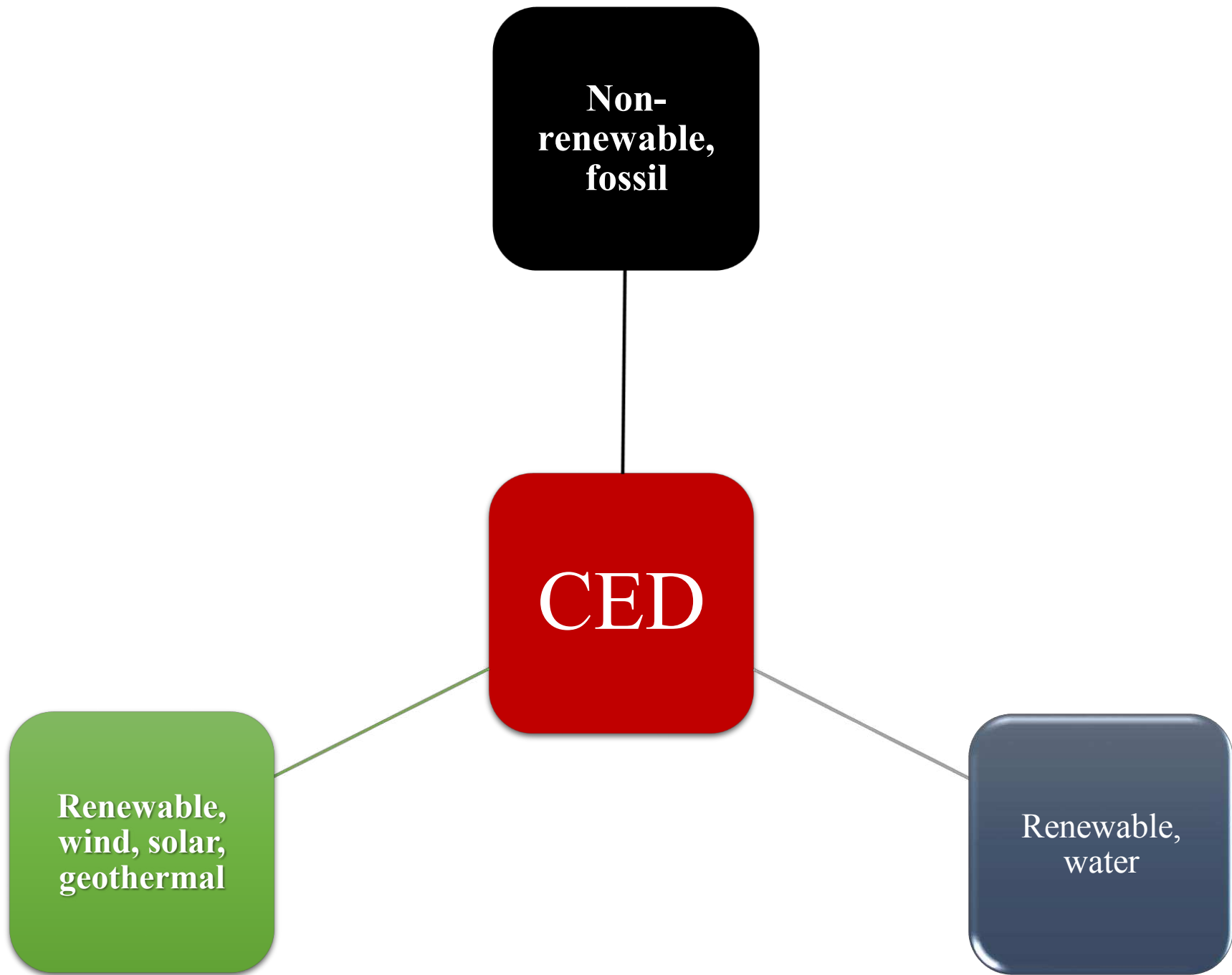
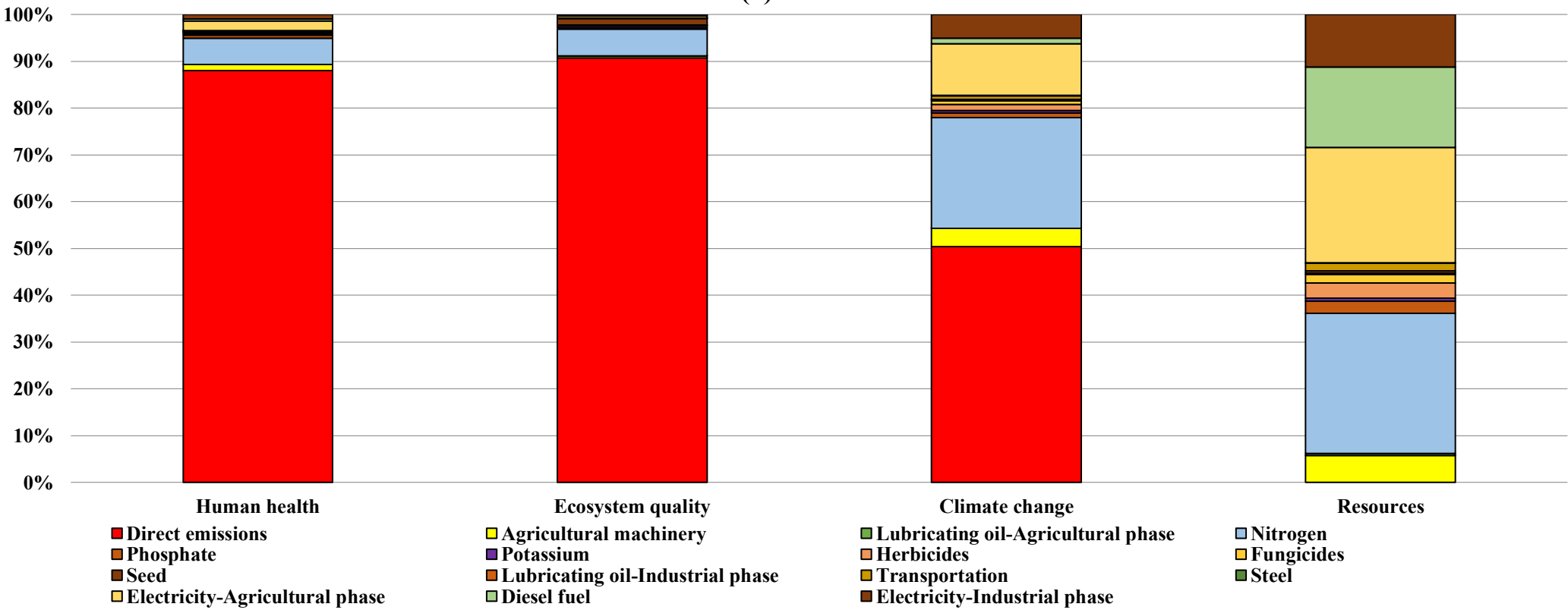

Fig. 6. Linking between midpoints and damage categories of IMPACT 2002+ method of LCA.

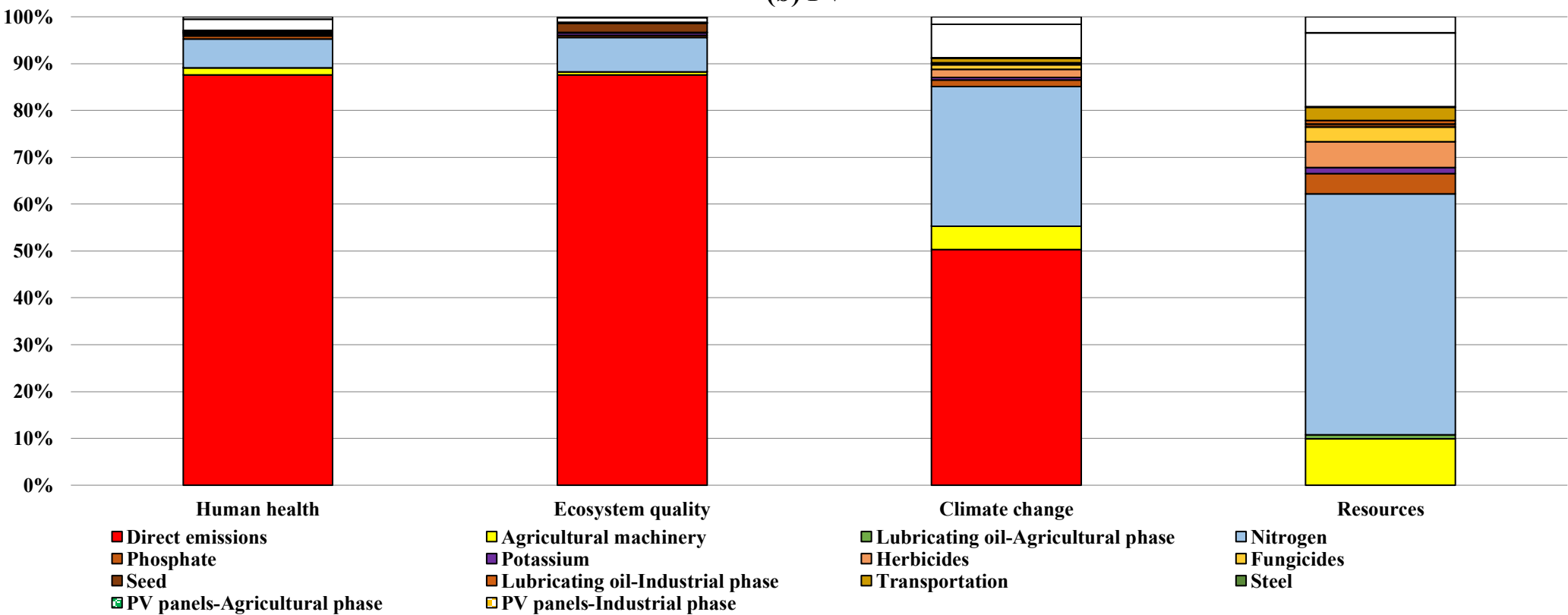

**Fig. 7.** Schematic diagram of CED energy indicators component.

(a) Present



(b) PV



(c) PV/T

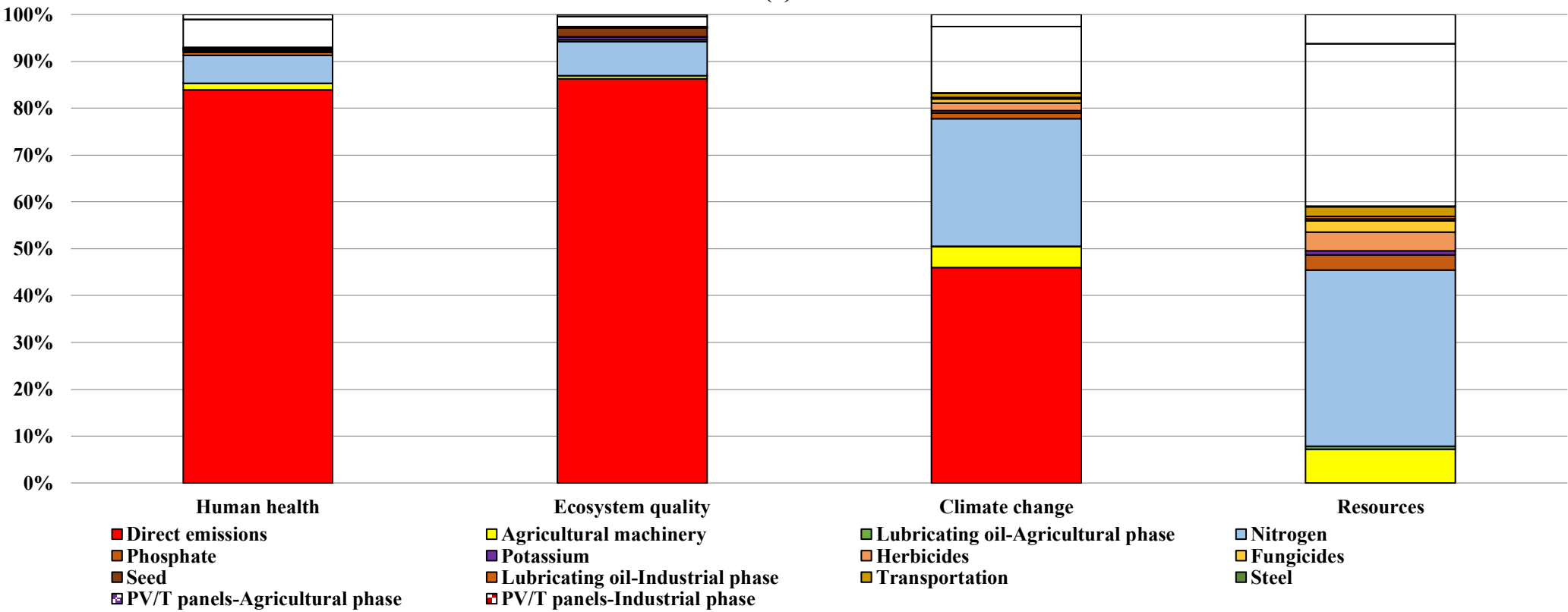
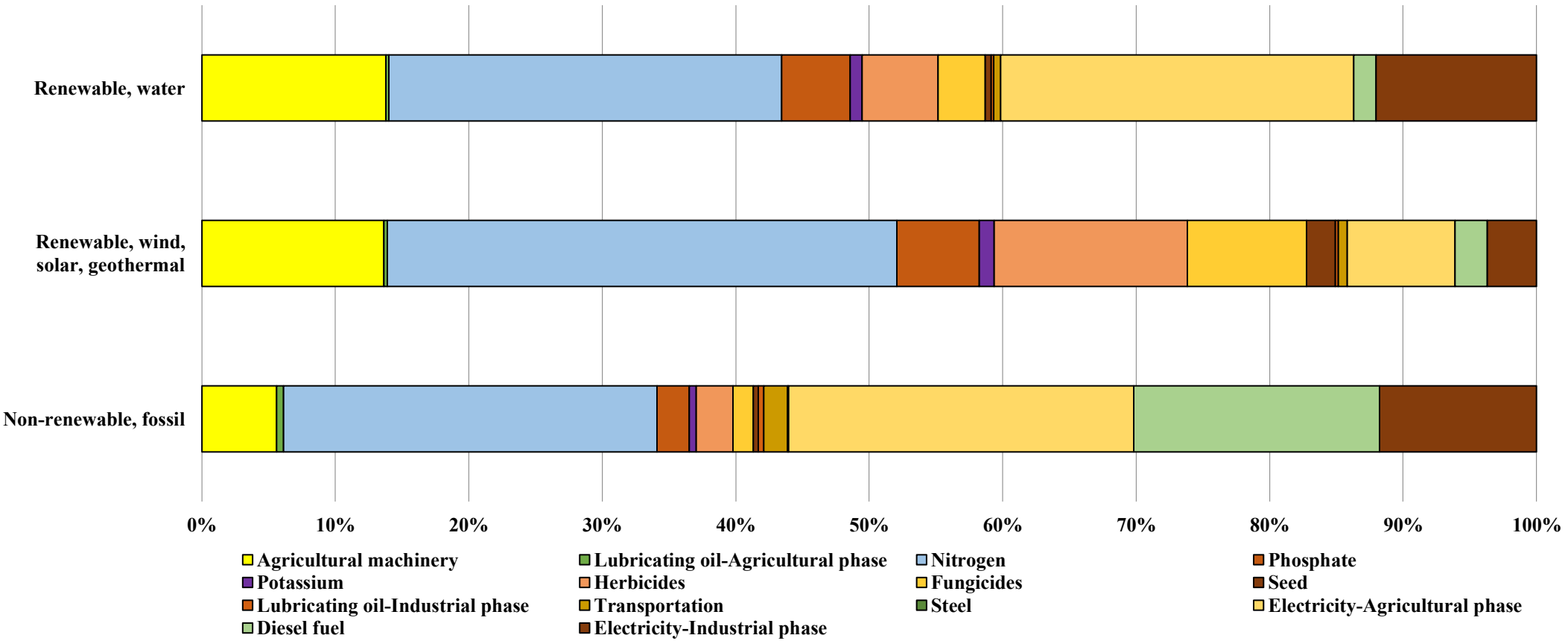
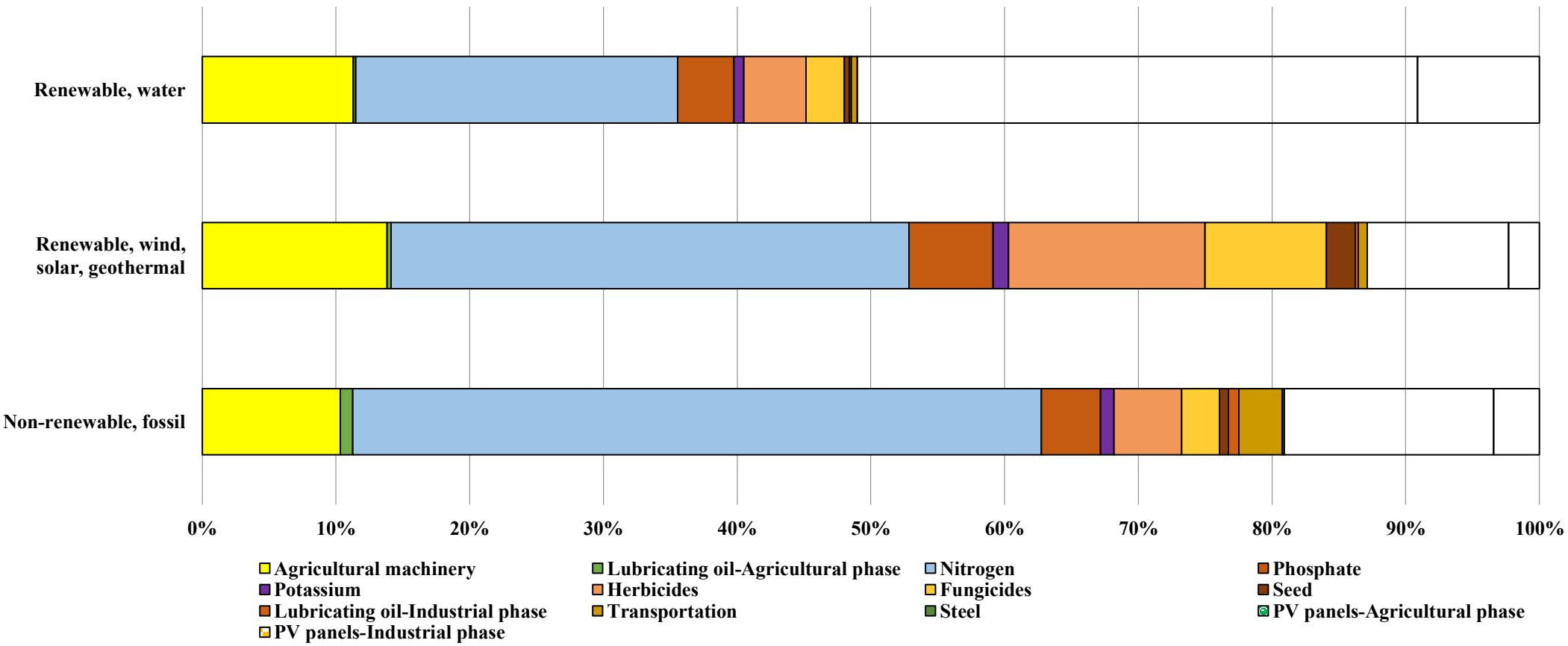

Fig. 8. The share of each inputs in the damage categories of SOP based on (a) Present, (b) PV and (c) PV/T scenarios.

(a) Present



(b) PV





(c) PV/T

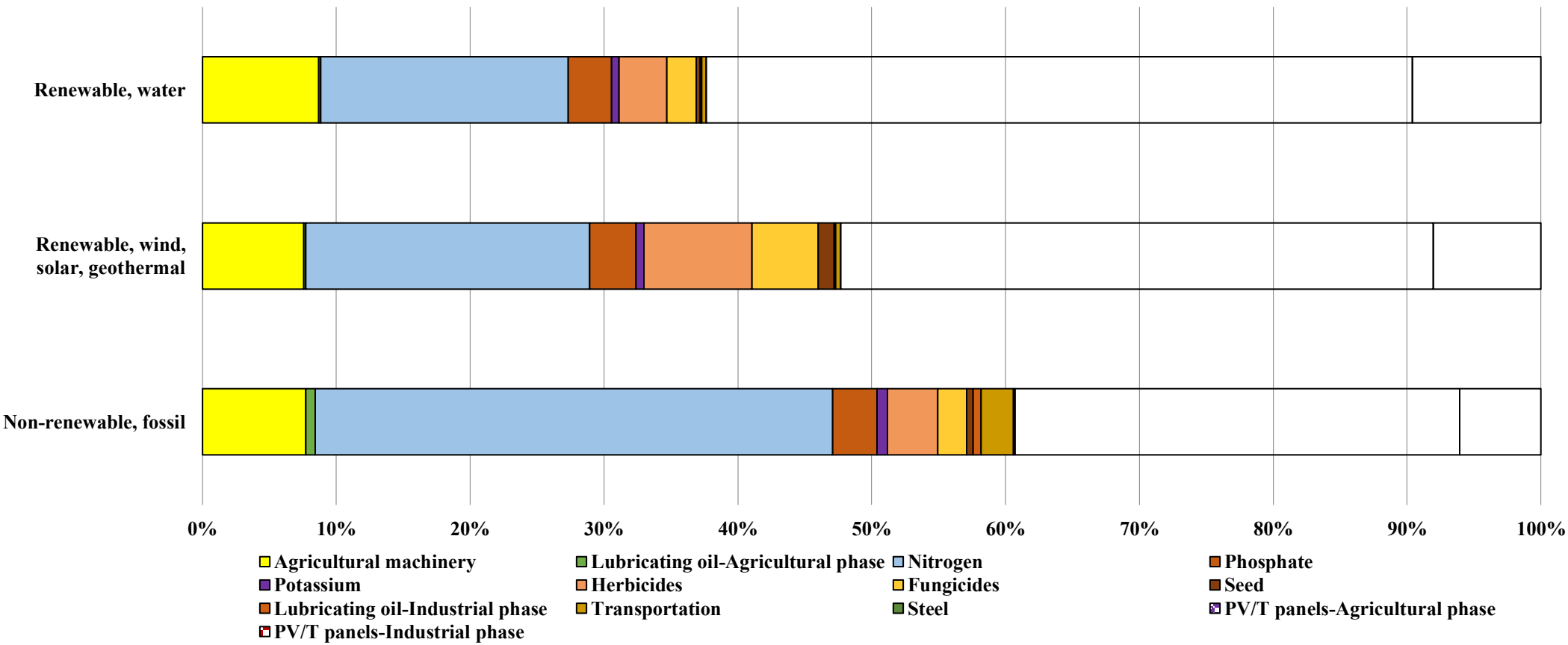
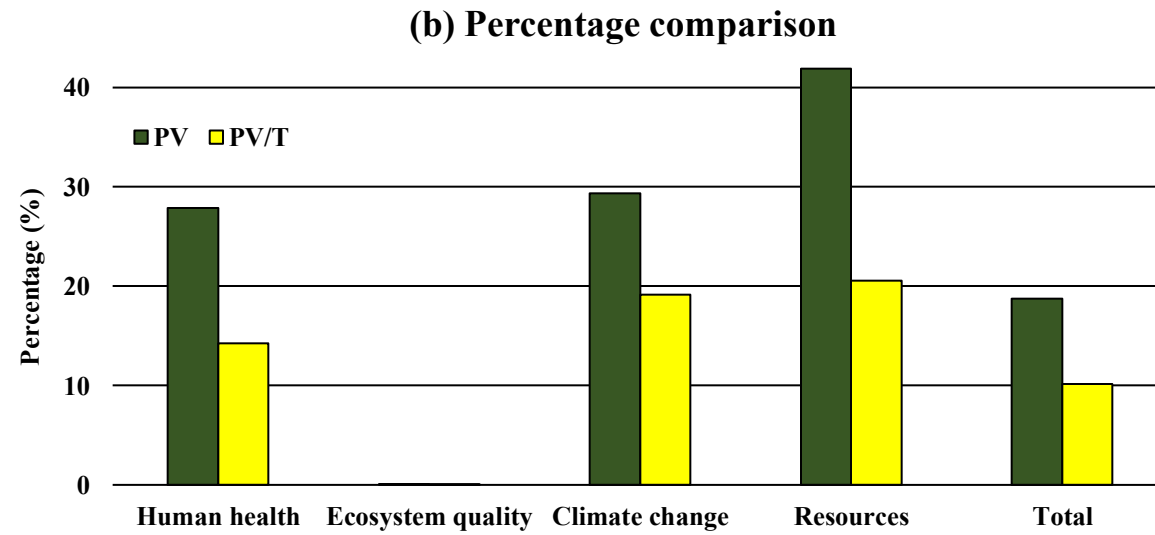
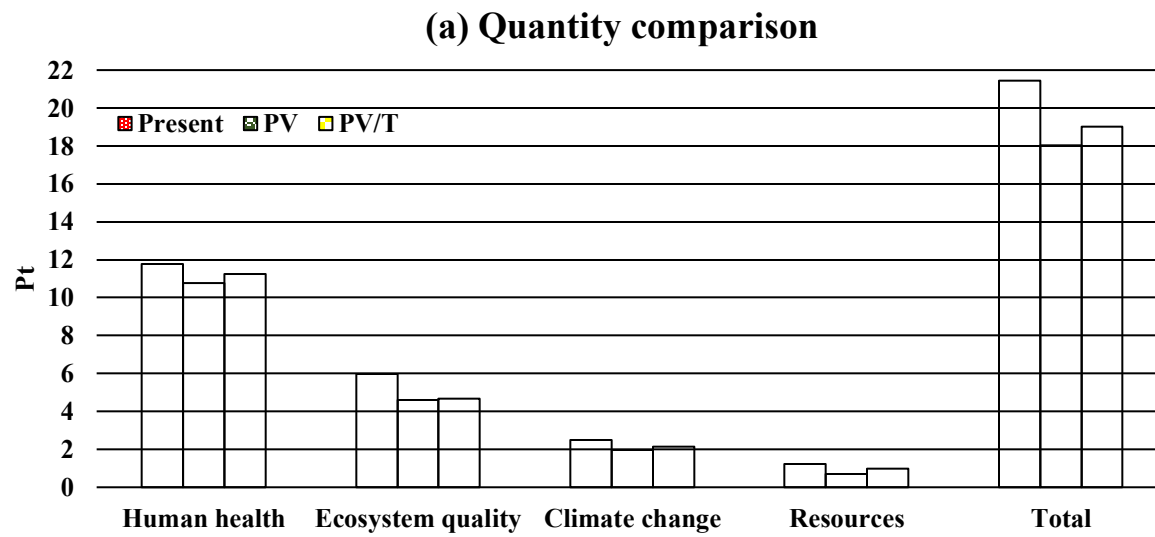
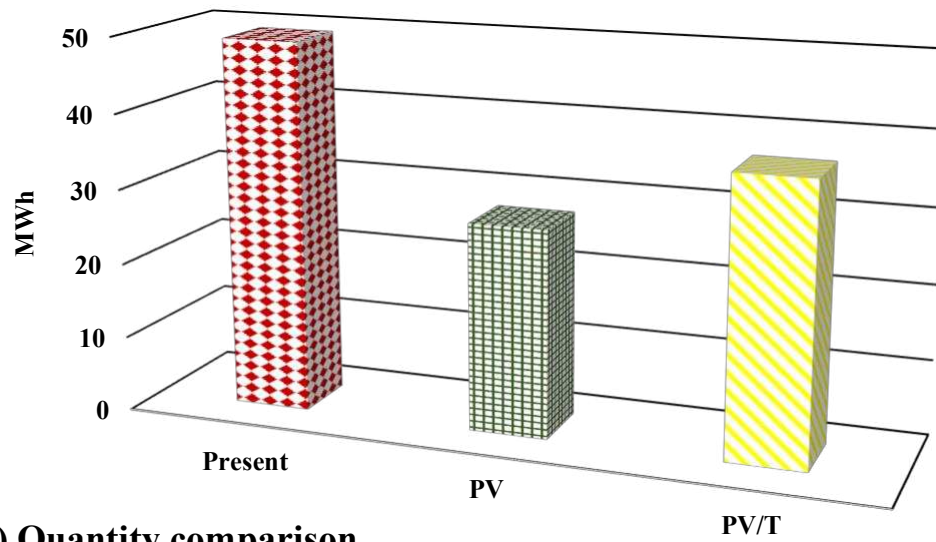

Fig. 9. The share of each inputs in energy forms of CED for SOP based on (a) Present, (b) PV and (c) PV/T scenarios.



**Fig. 10.** Comparison analysis of damages categories in defined scenarios of SOP.



**(a) Quantity comparison**

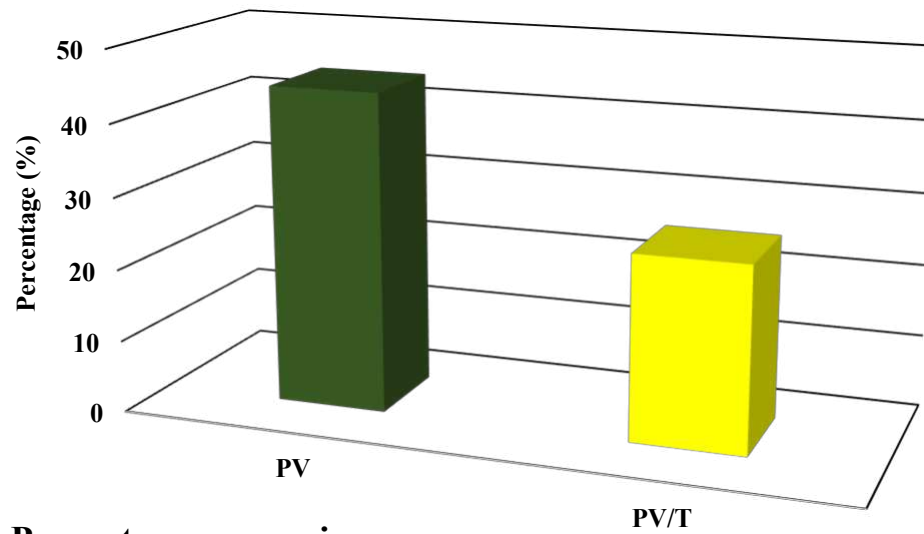

**(b) Percentage comparison**

**Fig. 11.** Comparison analysis of CED in defined scenarios of SOP.

### (a) Present

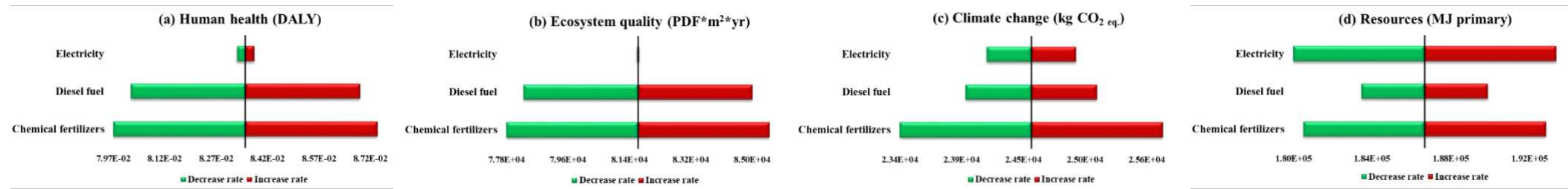

### (b) PV

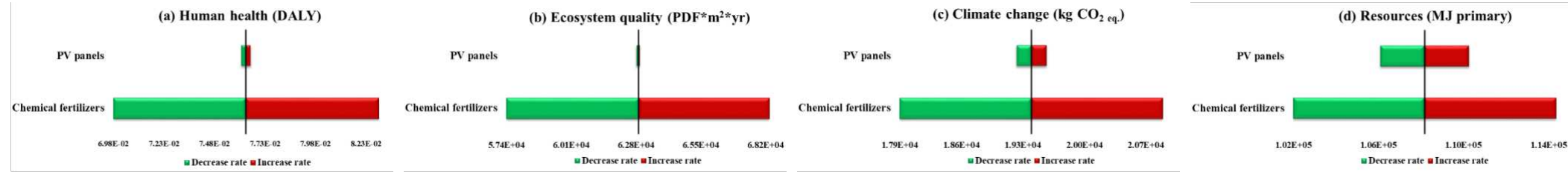

### (c) PV/T

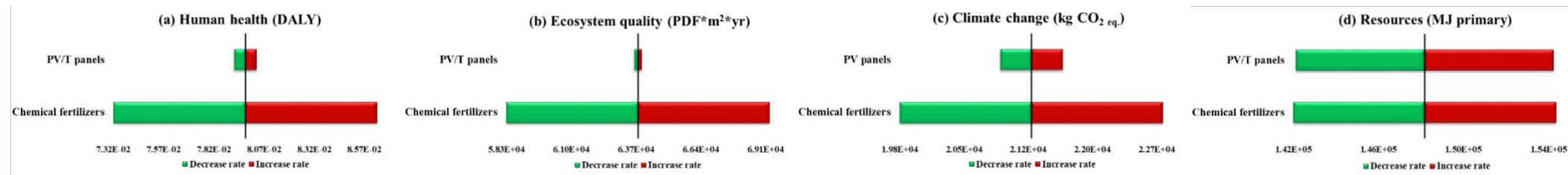

**Fig. 12.** The results of sensitivity analysis related to the effective input and output parameters of (a) Present, (b) PV and (c) PV/T scenarios of SOP.

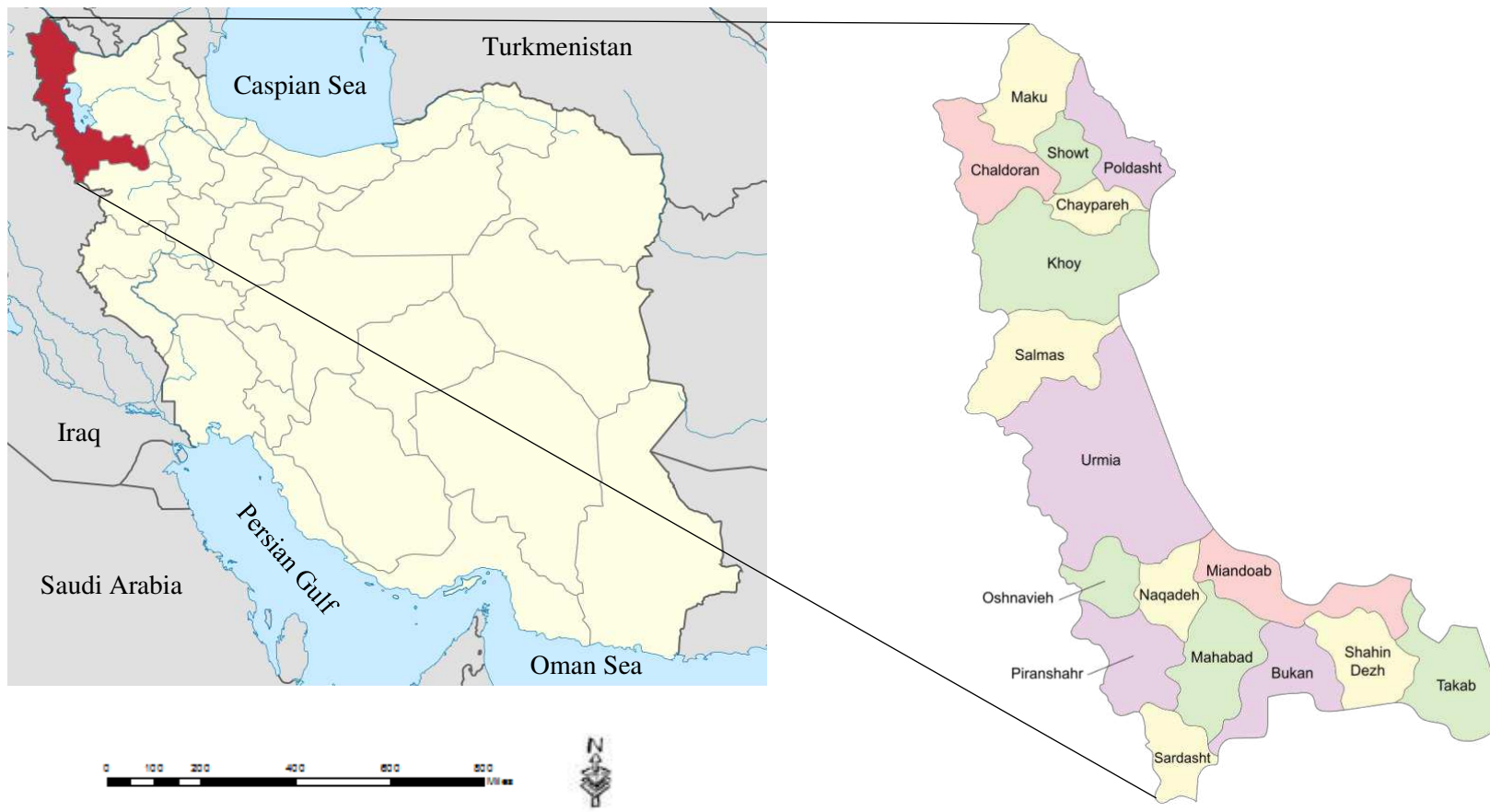

**Fig. 1.** Geographical position of the West Azerbaijan province in the northwest of Iran.

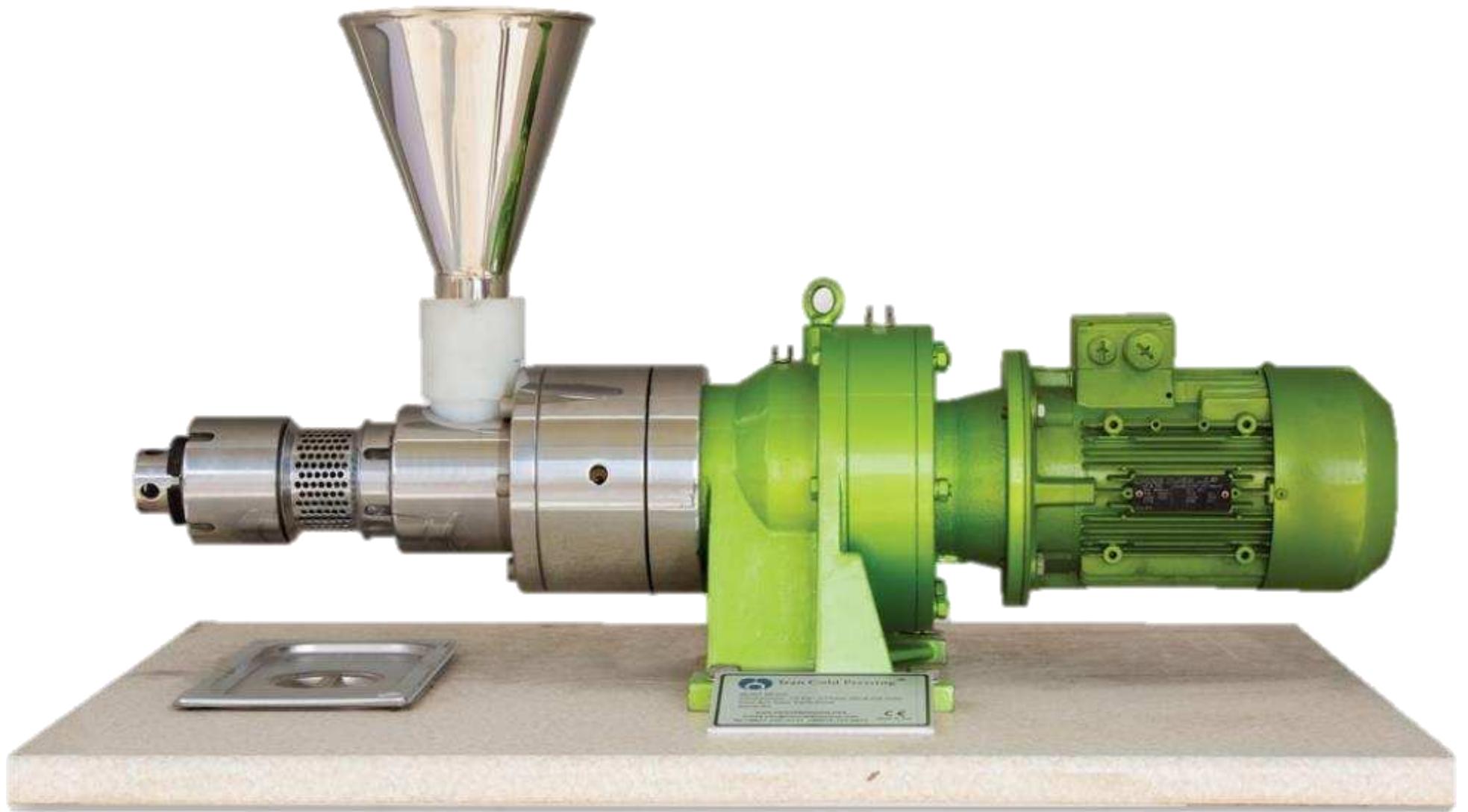

**Fig. 2.** The oil extraction equipment in the present study.

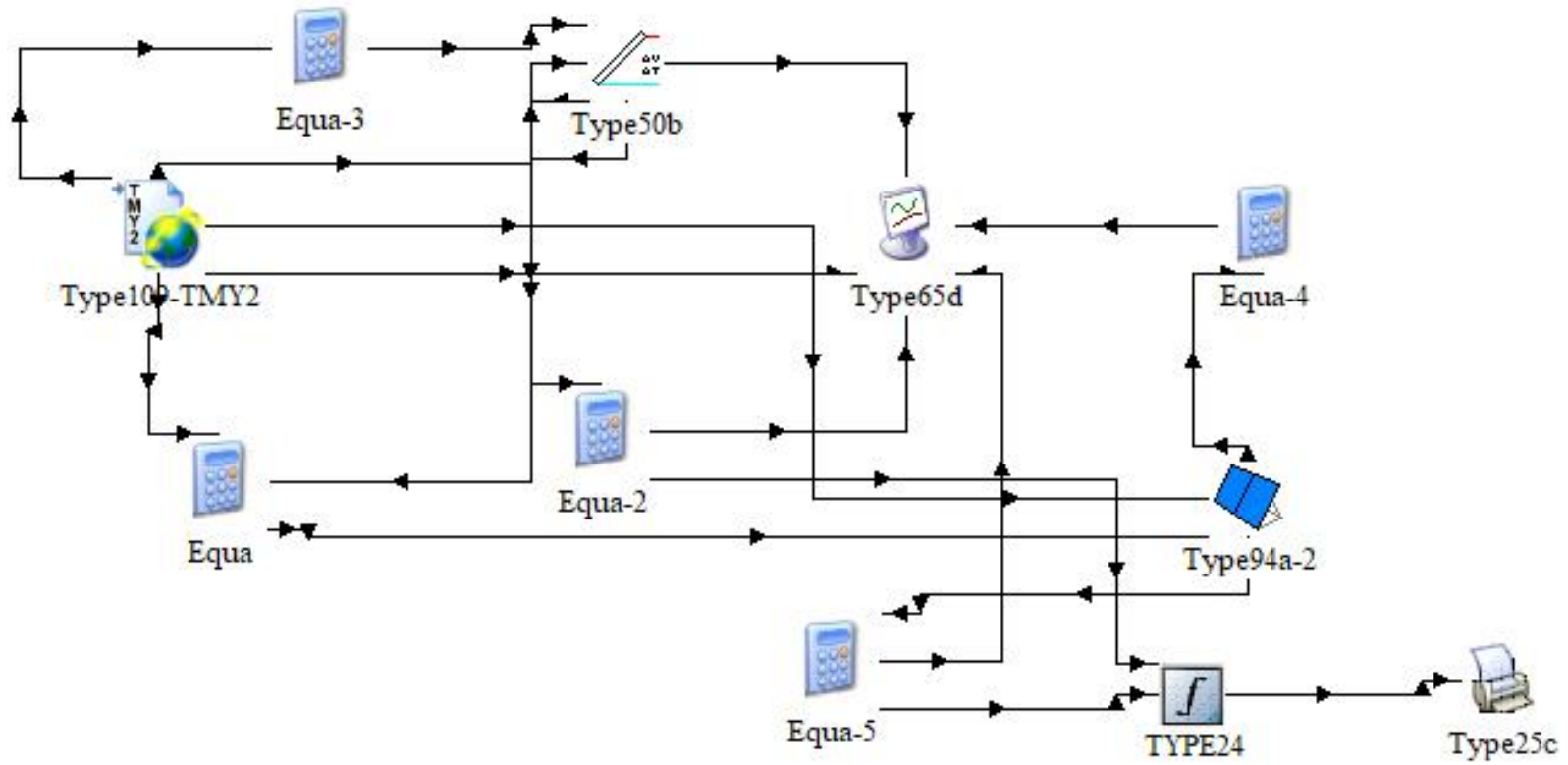

**Fig. 3.** Designed PV and PV/T circulate to establish SOP [59].

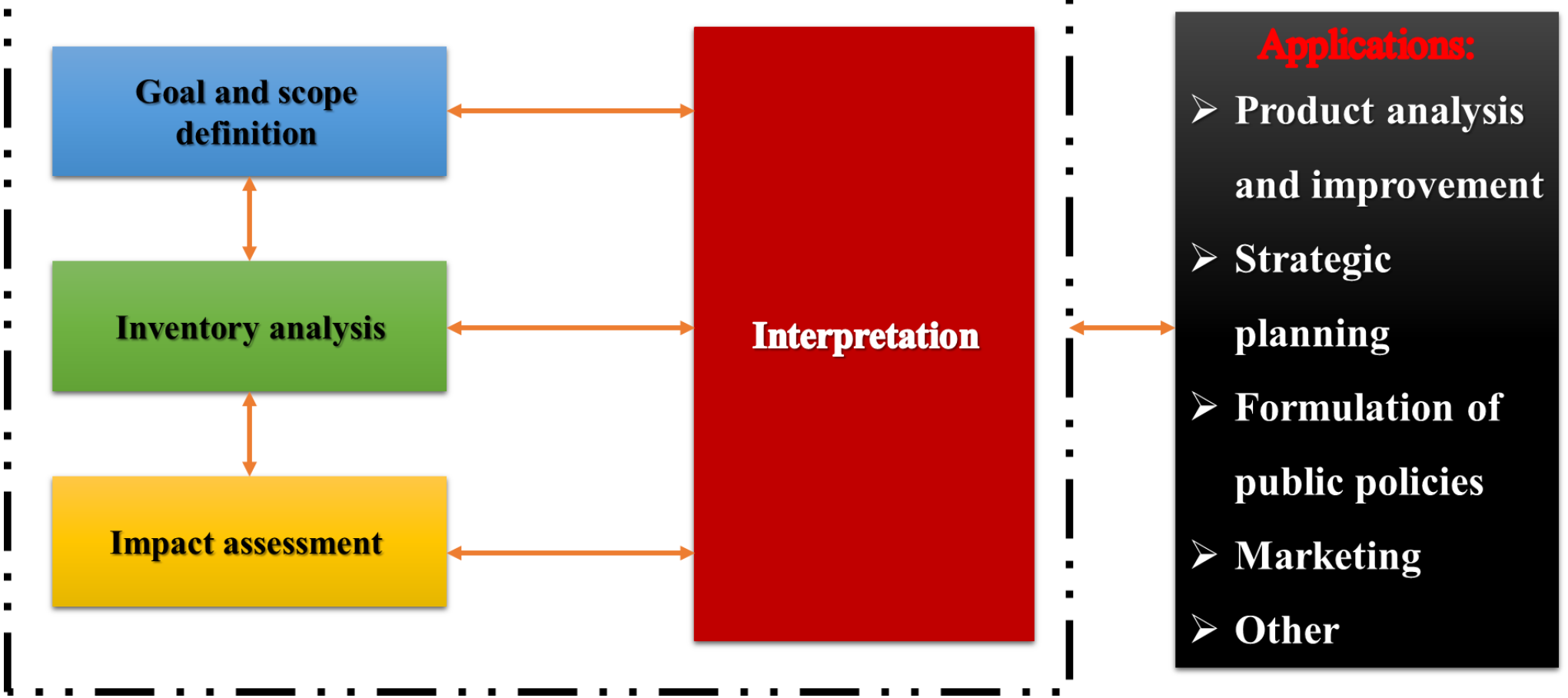

Fig. 4. Schematic diagram of LCA steps.



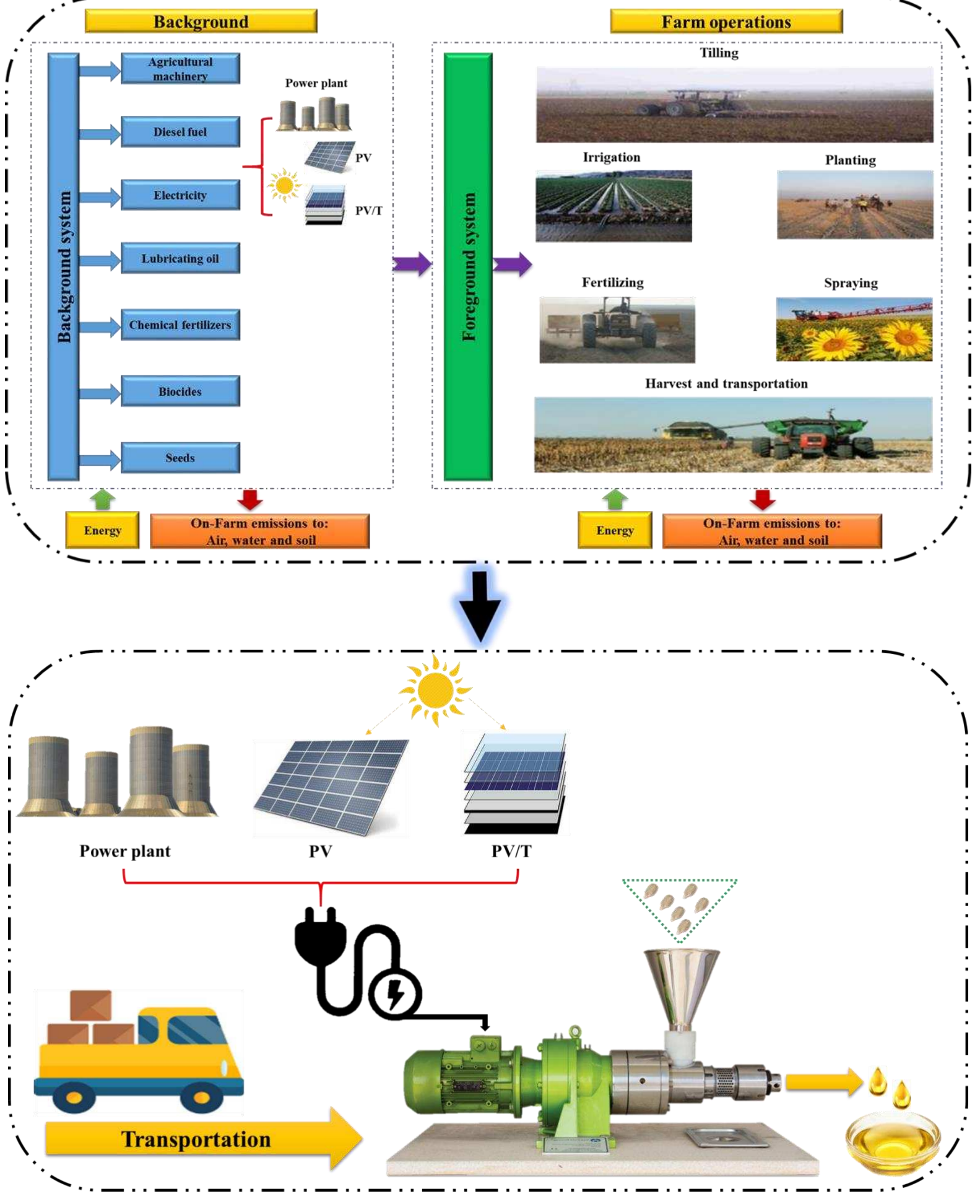
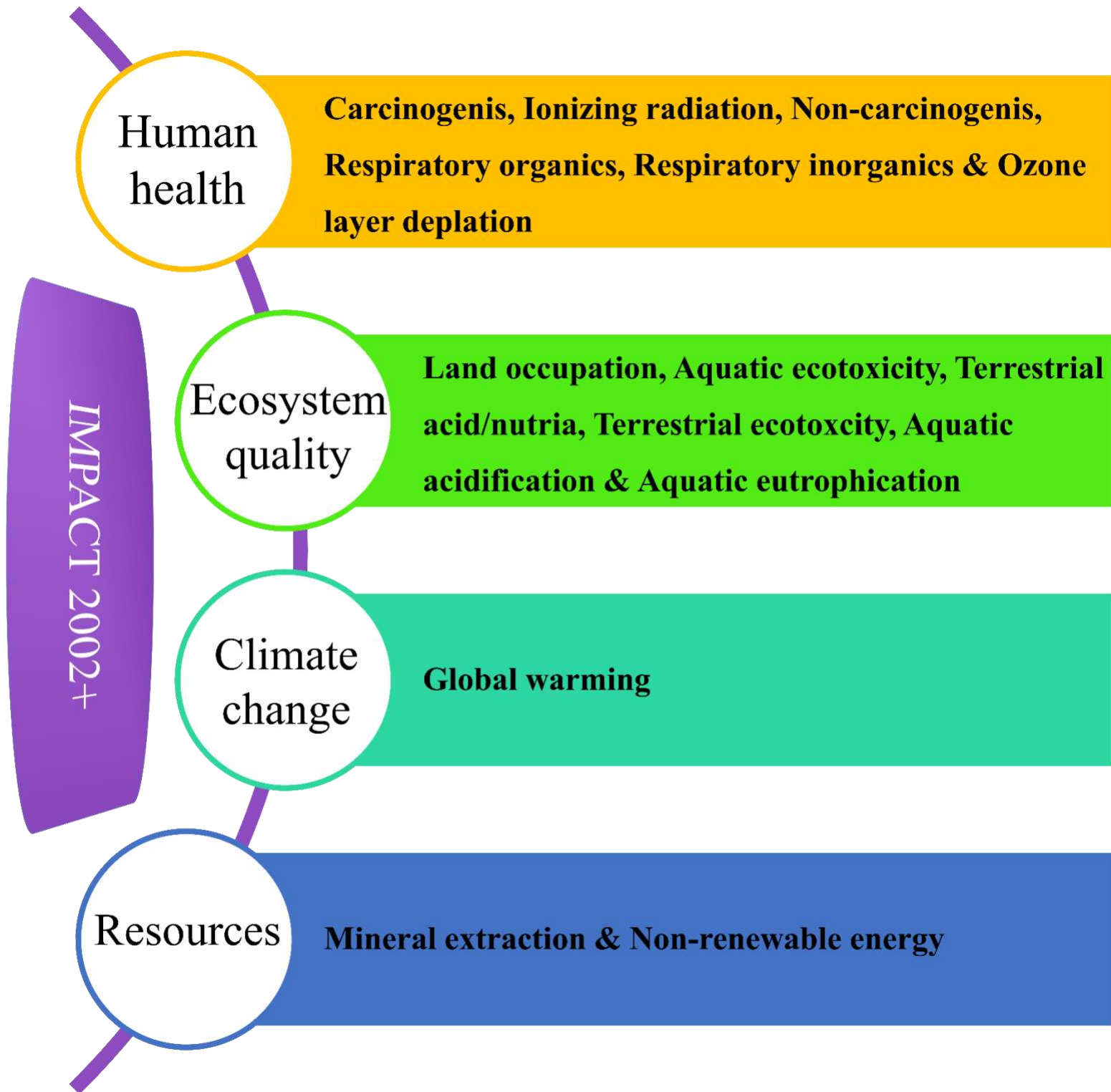
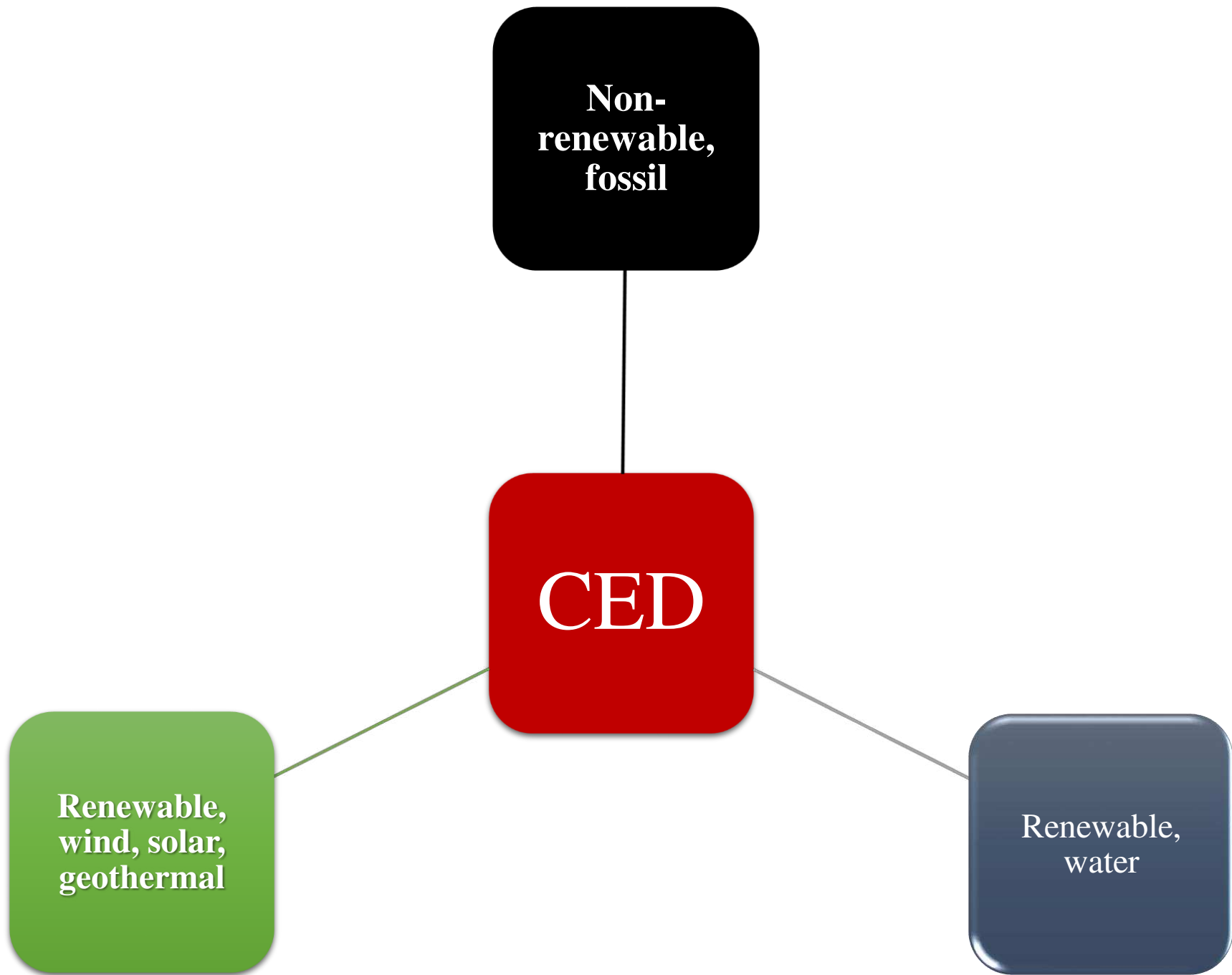

Fig. 5. System boundary including farm to industrial process of SOP.

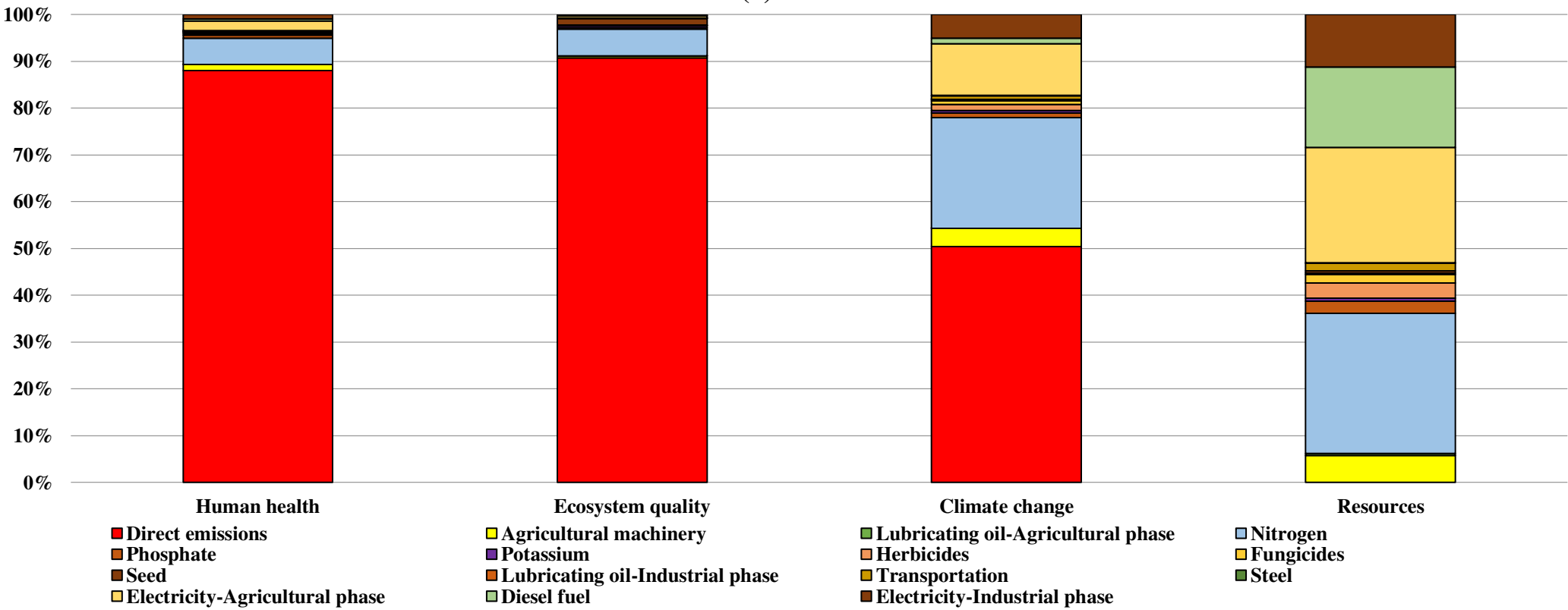

**Fig. 6.** Linking between midpoints and damage categories of IMPACT 2002+ method of LCA.

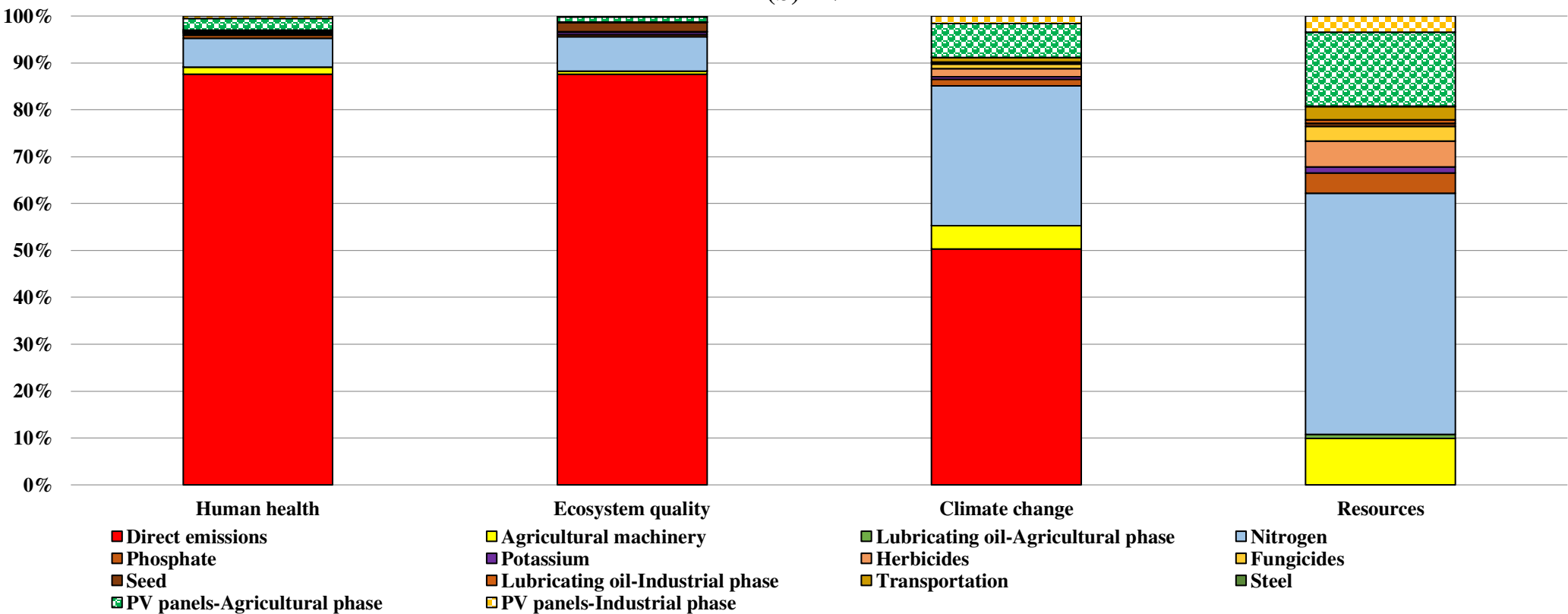

**Fig. 7.** Schematic diagram of CED energy indicators component.

(a) Present



(b) PV



(c) PV/T

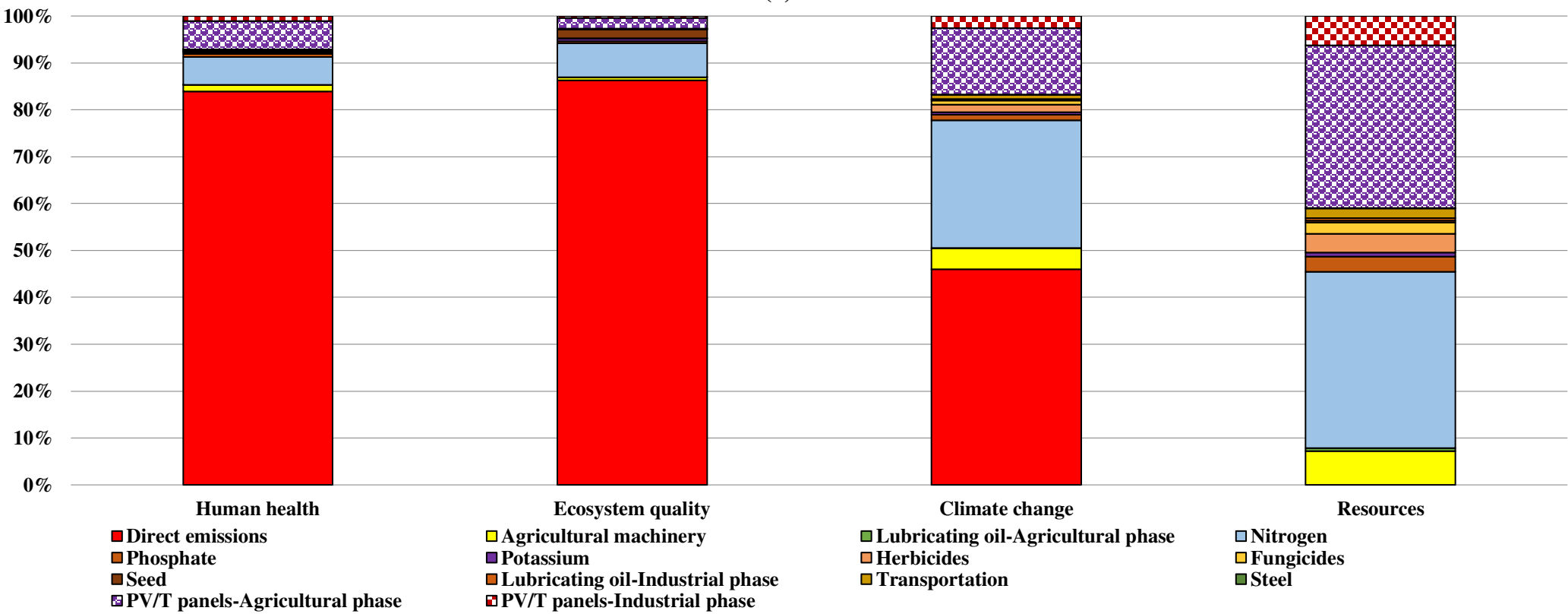
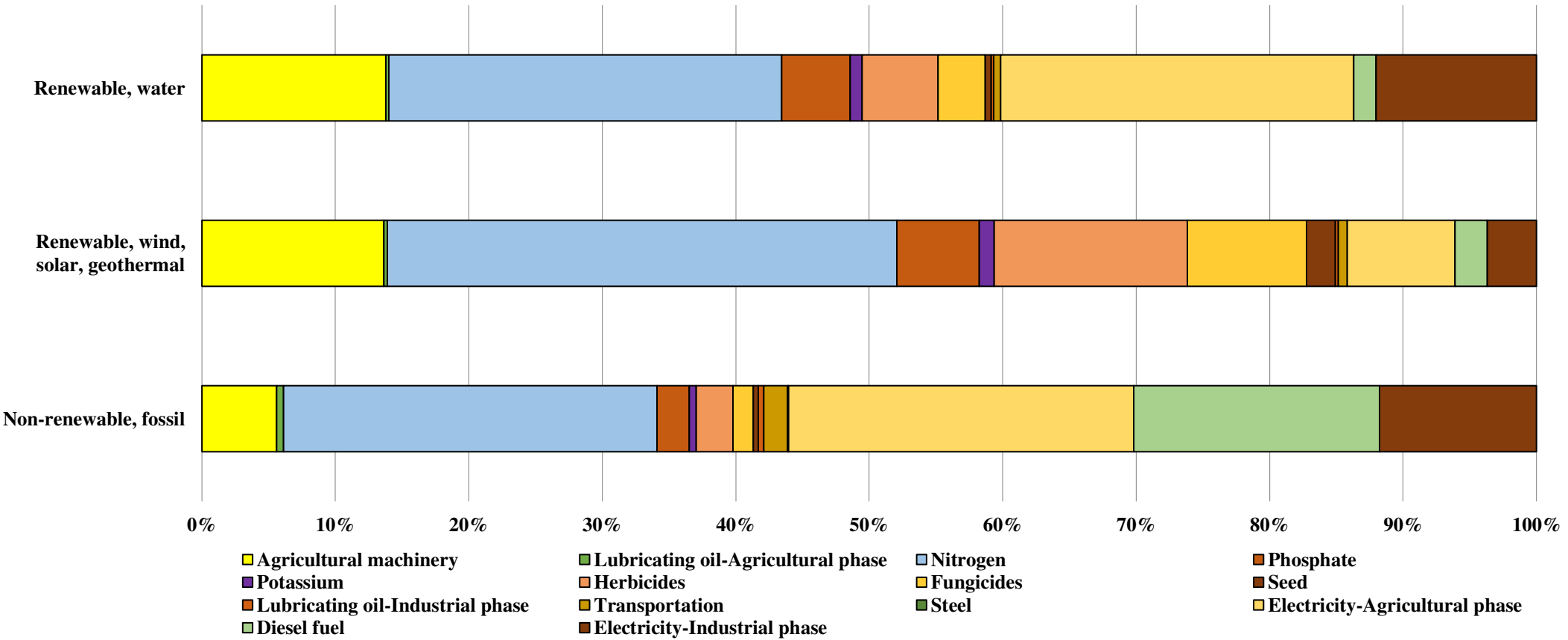
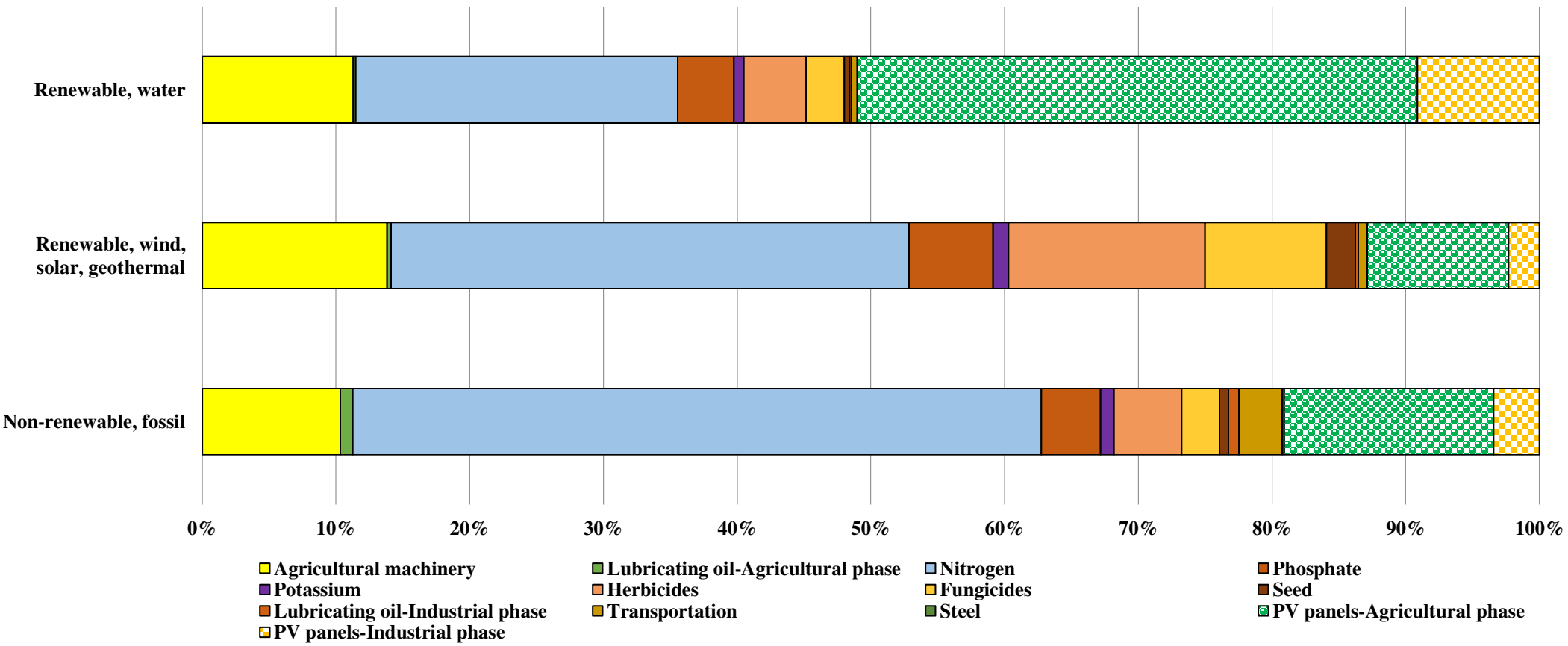

Fig. 8. The share of each inputs in the damage categories of SOP based on (a) Present, (b) PV and (c) PV/T scenarios.

(a) Present



(b) PV





(c) PV/T

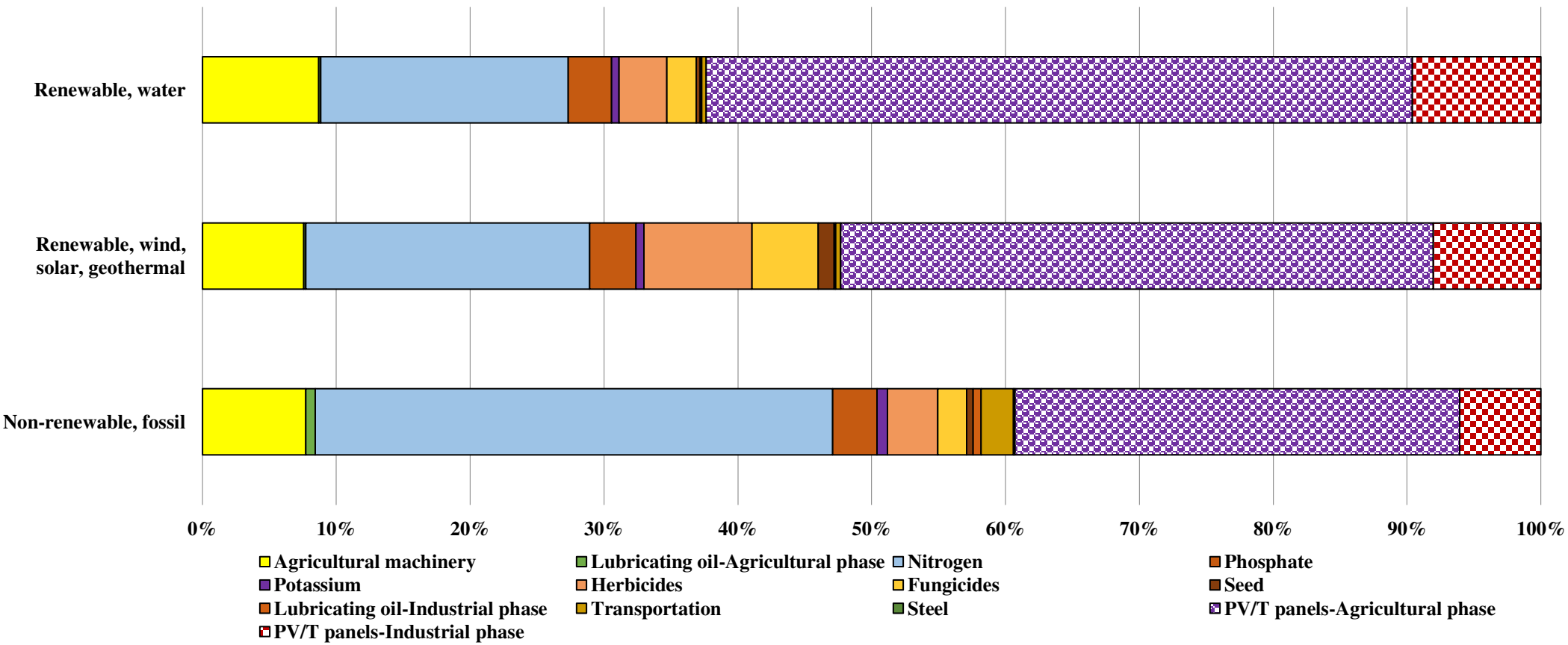
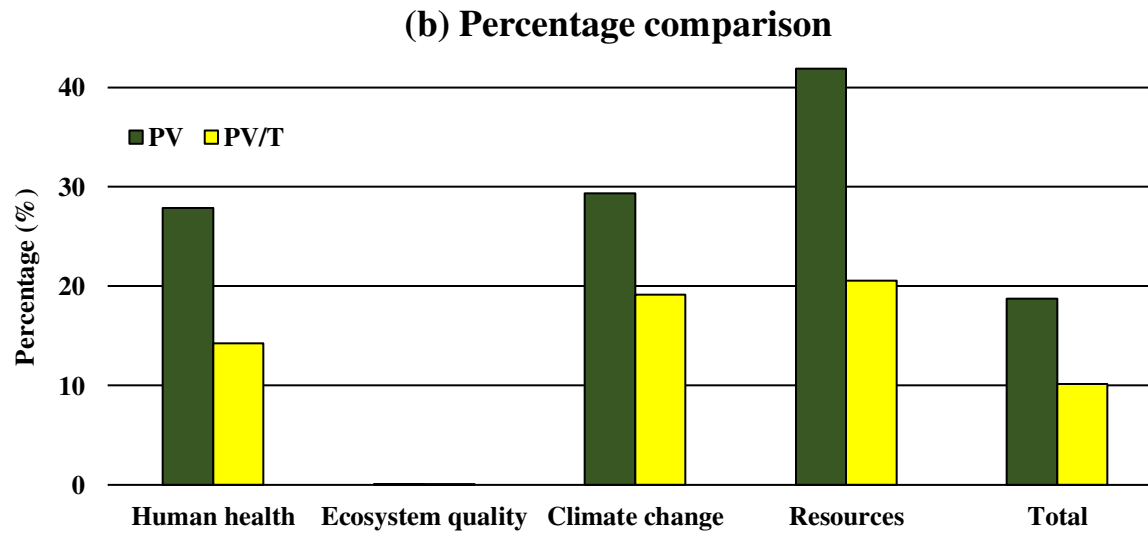
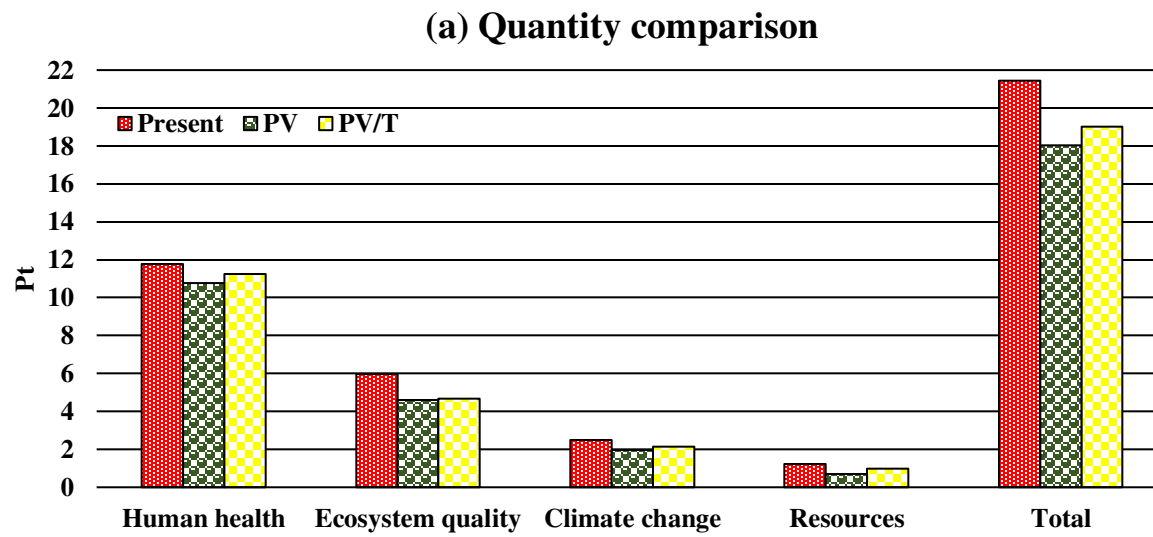
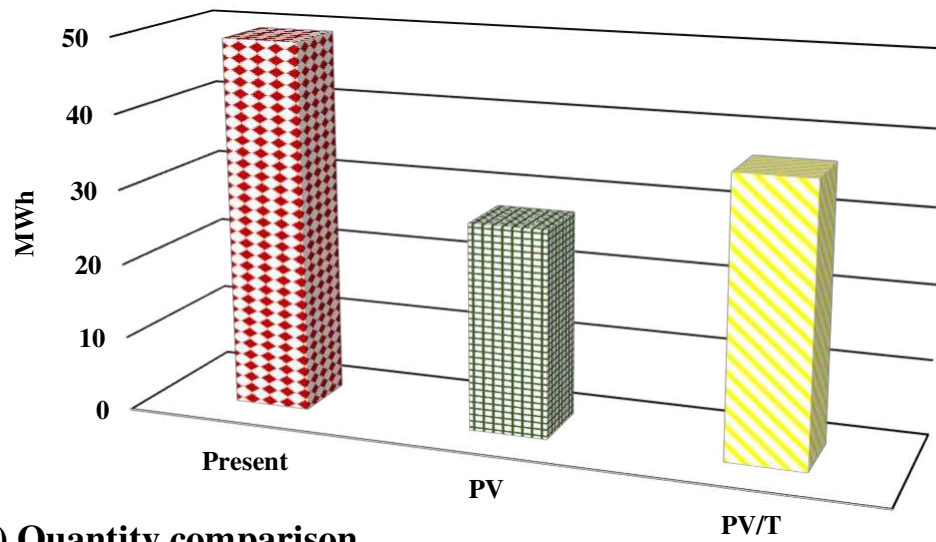

Fig. 9. The share of each inputs in energy forms of CED for SOP based on (a) Present, (b) PV and (c) PV/T scenarios.



**Fig. 10.** Comparison analysis of damages categories in defined scenarios of SOP.



**(a) Quantity comparison**

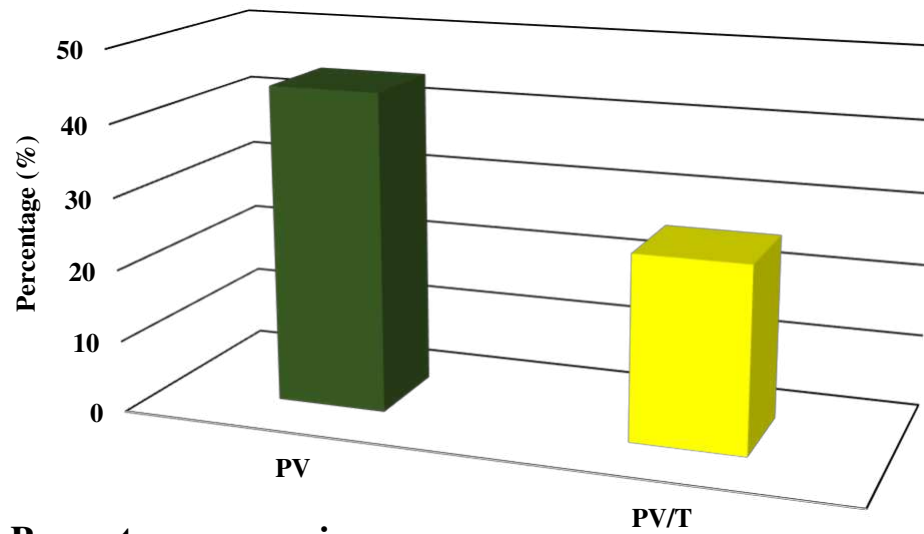

**(b) Percentage comparison**

**Fig. 11.** Comparison analysis of CED in defined scenarios of SOP.

### (a) Present

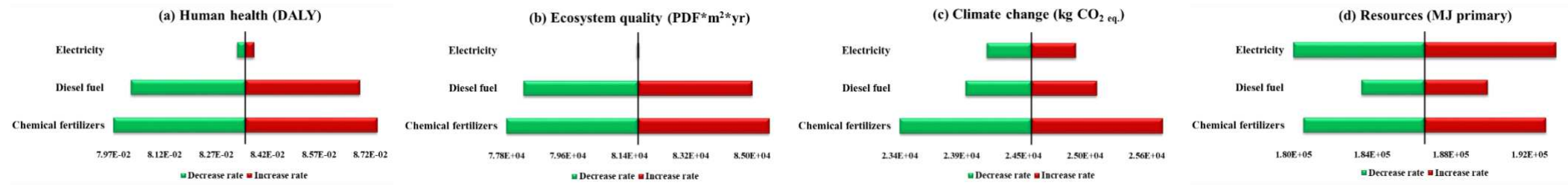

### (b) PV

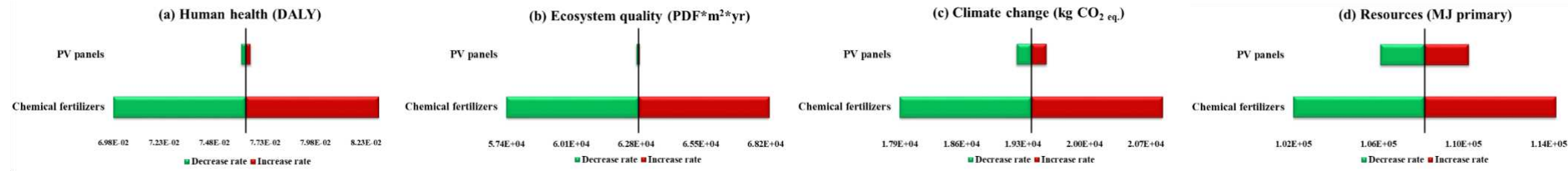

### (c) PV/T

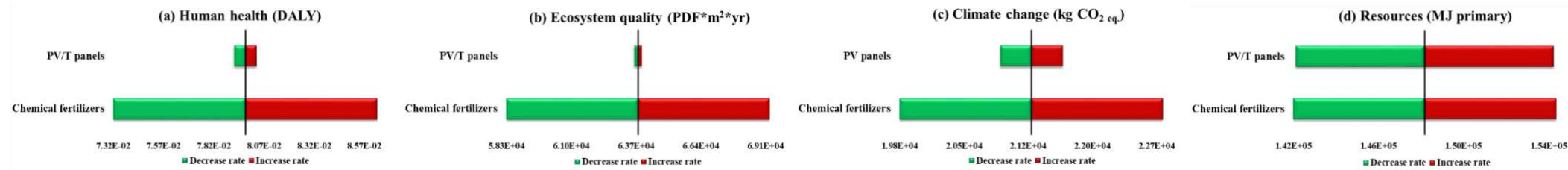

**Fig. 12.** The results of sensitivity analysis related to the effective input and output parameters of (a) Present, (b) PV and (c) PV/T scenarios of SOP.